

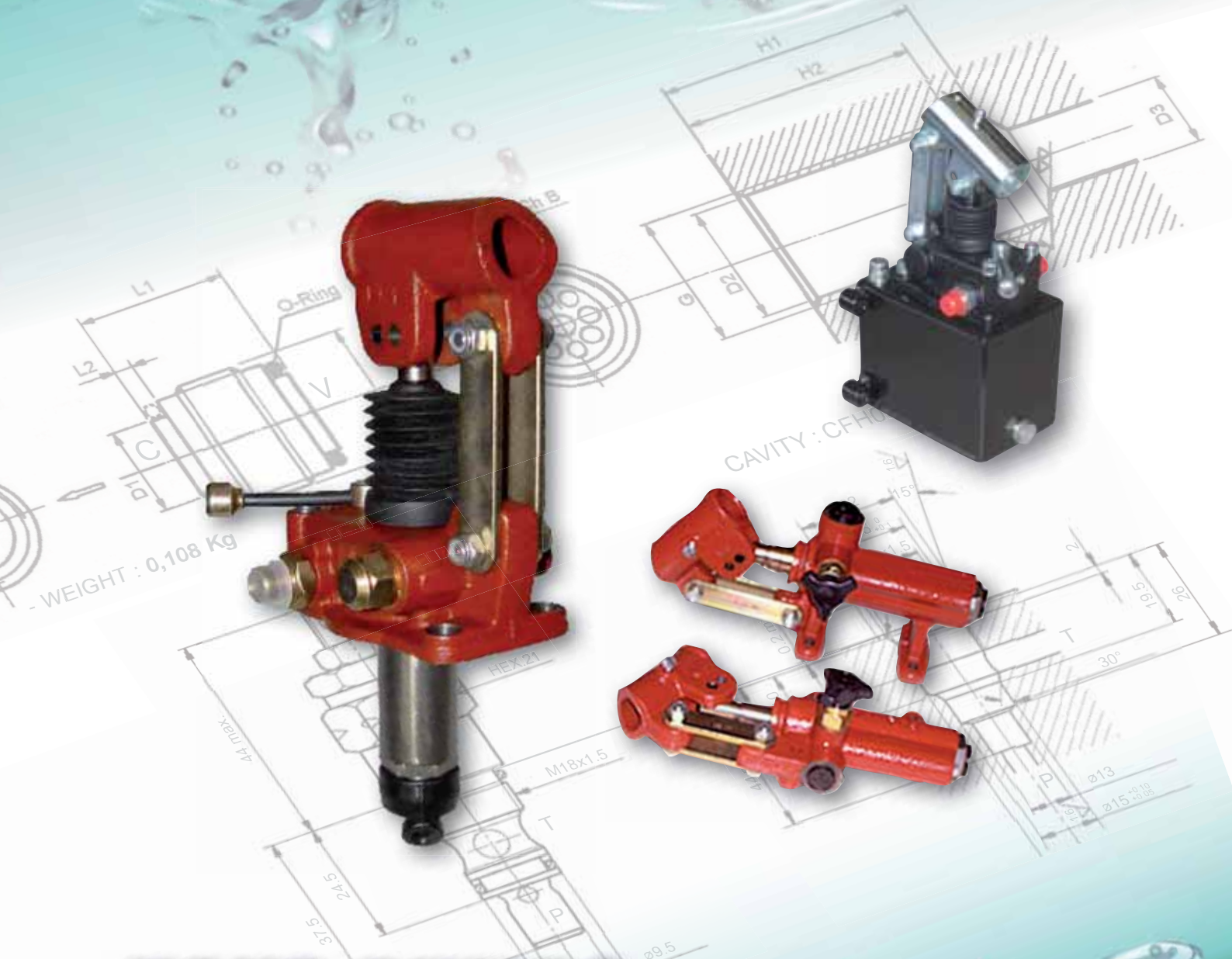

FER
HYDRAULIK
COMPONENTI OLEODINAMICI



HAND PUMPS CATALOGUE

INDEX

code	description	pag
	Hand pumps	
PMP 20	Hand pump	4
PMO 50	Hand pump	9
PMO 70	Hand pump	14
PM 12-25-45	Hand pump	19
PMD 12-25-45	Hand pump	27
PMDVB 12-25-45	Hand pump	31
PM 8-15	Hand pump	34
PM 20-30-40	Hand pump	38
PM2V 5-80	Hand pump	44
	Levers for hand pumps	56
	Painted steel oil tanks for hand pump	57

POMPA A MANO HAND PUMP

**TIPO
TYPE**

PMP 20

POMPA A MANO PMP 20 con volantino di scarico	HAND PUMP PMP 20 with exhaust handwheel
Pompa doppio effetto per cilindro a semplice effetto per montaggio a parete	Double-acting pump for a single-acting cylinder for fixing to wall

Tipo di pompa Type of pump	Cilindr.(cm ³) Flow (cm ³)	Pressione (Pressure)(bar) eserciz.(exerciz.)		Massa (Kg) Weight(Kg)	Codice senza soffiet. Code without bellows	Codice con soffiet. Code with bellows
			max.			
PMP 20	20,09	280	350	2,650	60740000	60740027

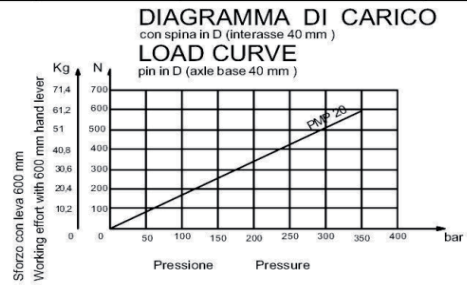
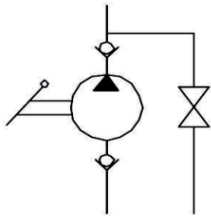

PMP 20

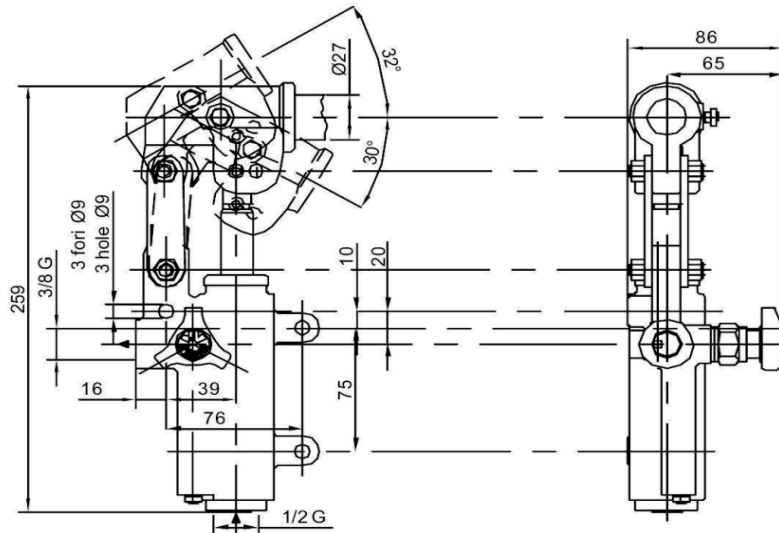

PMP 20 s

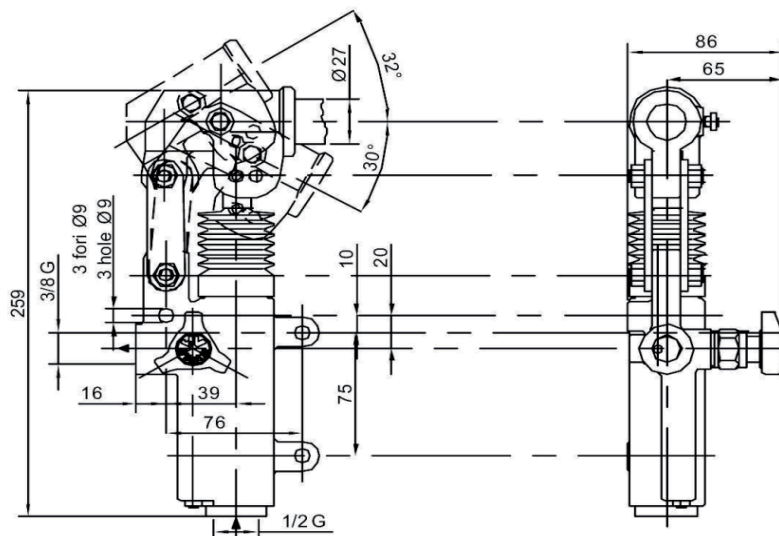

POMPA A MANO HAND PUMP

TIPO
TYPE

PMP 20

POMPA A MANO PMP 20 senza volantino di scarico	HAND PUMP PMP 20 without exhaust handwheel
Pompa doppio effetto per cilindro a semplice effetto per montaggio a parete	Double-acting pump for a single-acting cylinder for fixing to wall

Tipo di pompa Type of pump	Cilindr.(cm ³) Flow (cm ³)	Pressione (Pressure)(bar)		Massa (Kg) Weight(Kg)	Codice senza soffiet. Code without bellows	Codice con soffiet. Code with bellows
		eserciz.(exerciz.)	max.			
PMP 20	20,09	280	350	2,650	60740001	60740028



DIAGRAMMA DI CARICO
con spina in D (interasse 40 mm)
LOAD CURVE
pin in D (axle base 40 mm)



PMP 20 e

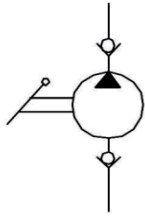
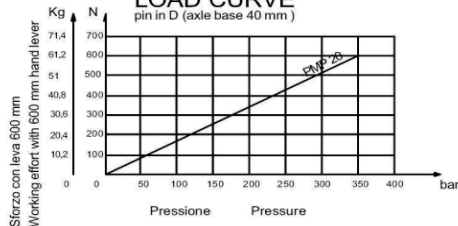
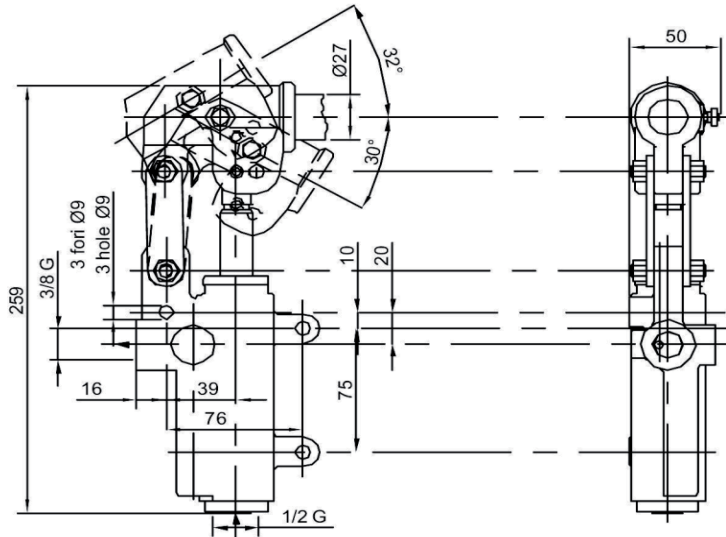

PMP 20 e-s

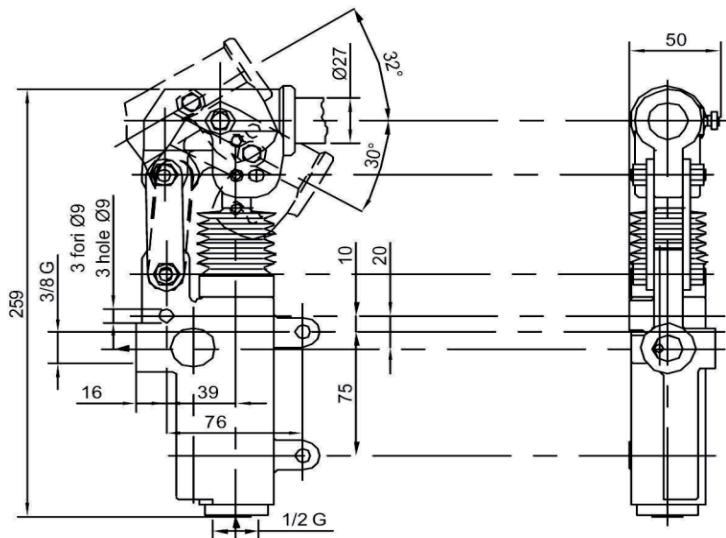

POMPA A MANO HAND PUMP

TIPO
TYPE

PMP 20

POMPA A MANO PMP 20 con manipolatore	HAND PUMP PMP 20 with release manipolator
Pompa doppio effetto per cilindro a semplice effetto per montaggio a parete	Double-acting pump for a single-acting cylinder for fixing to wall

Tipo di pompa Type of pump	Cilindr. (cm ³) Flow (cm ³)	Pressione (Pressure) (bar)		Massa (Kg) Weight (Kg)	Codice senza soffiet. Code without bellows	Codice con soffiet. Code with bellows
		eserciz. (exerciz.)	max.			
PMP 20	20,09	280	350	2,650	60740002	60740029

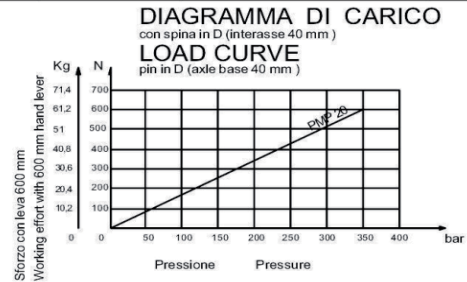
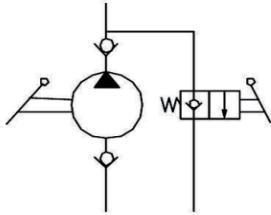

PMP 20 m

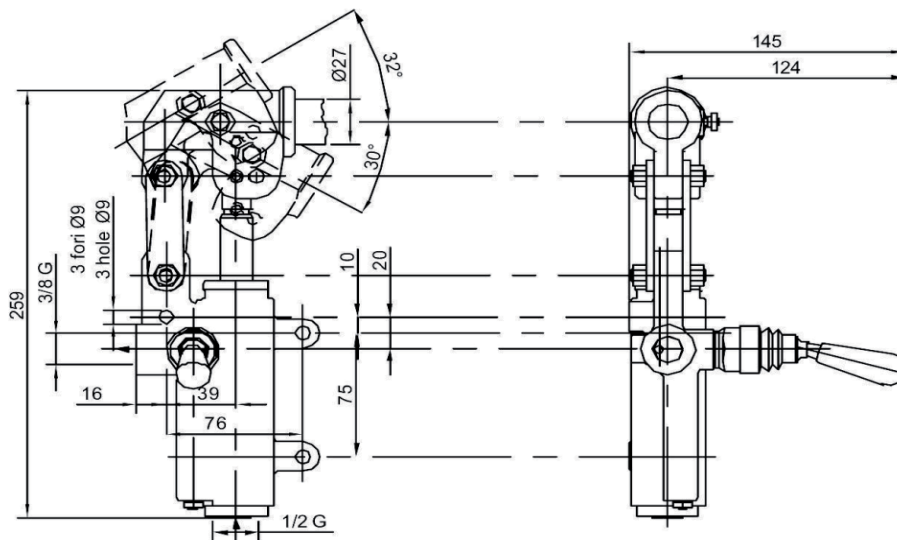

PMP 20 m-s

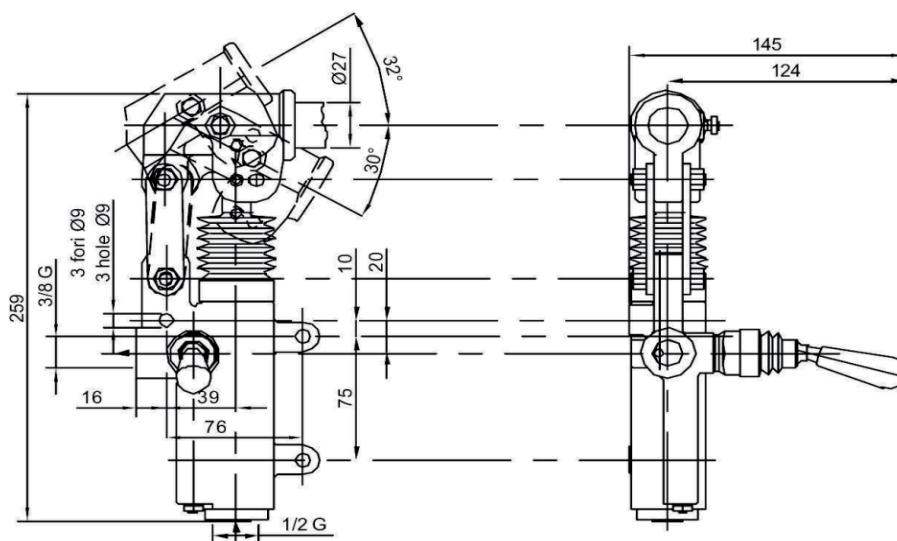

POMPA A MANO HAND PUMP

TIPO
TYPE

PMP 20

POMPA A MANO PMP 20
con leva di scarico

HAND PUMP PMP 20
with release lever

Pompa doppio effetto per cilindro a semplice effetto
per montaggio a parete

Double-acting pump for a single-acting cylinder
for fixing to wall

Tipo di pompa Type of pump	Cilindr. (cm ³) Flow (cm ³)	Pressione (Pressure) (bar)		Massa (Kg) Weight (Kg)	Codice senza soffiet. Code without bellows	Codice con soffiet. Code with bellows
		eserciz. (exerciz.)	max.			
PMP 20	20,09	280	350	2,650	60740003	60740030



DIAGRAMMA DI CARICO
con spina in D (interasse 40 mm)
LOAD CURVE
pin in D (axle base 40 mm)



PMP 20 L

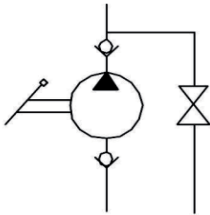
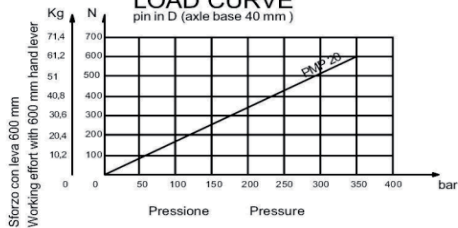
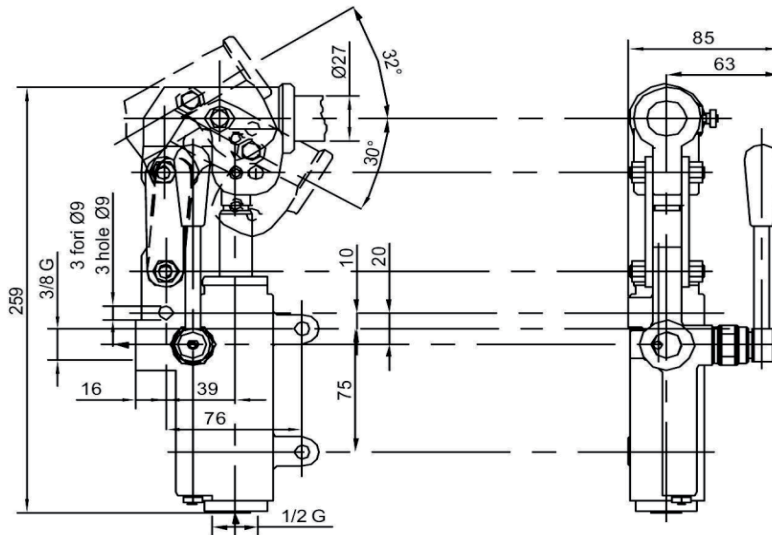

PMP 20 L-s

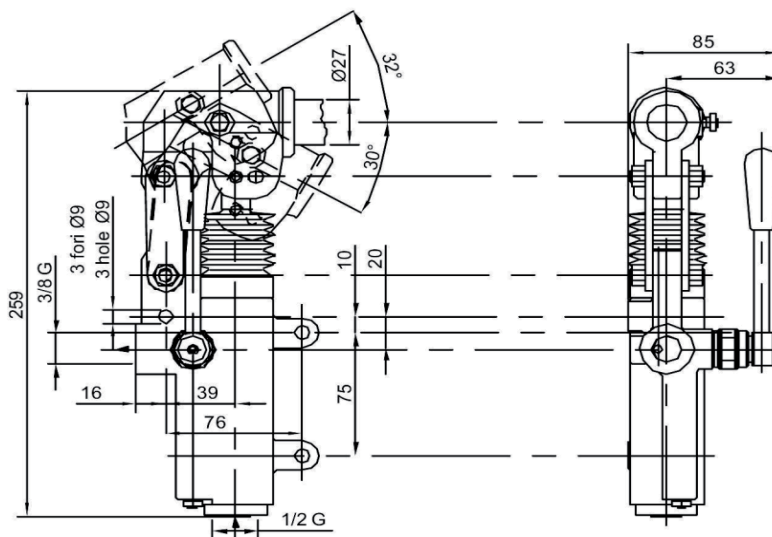

POMPA A MANO HAND PUMP

TIPO
TYPE

PMP 20

POMPA A MANO PMP 20 senza volantino di scarico con valvola di by-pass	HAND PUMP PMP 20 without exhaust handwheel with pressure relief valve
Pompa doppio effetto per cilindro a semplice effetto per montaggio a parete	Double-acting pump for a single-acting cylinder for fixing to wall

Tipo di pompa Type of pump	Cilindr.(cm ³) Flow (cm ³)	Pressione (Pressure)(bar)		Massa (Kg) Weight(Kg)	Codice senza soffiet. Code without bellows	Codice con soffiet. Code with bellows
		eserciz.(exerciz.)	max.			
PMP 20	20,09	280	350	2,650	60740004	60740031

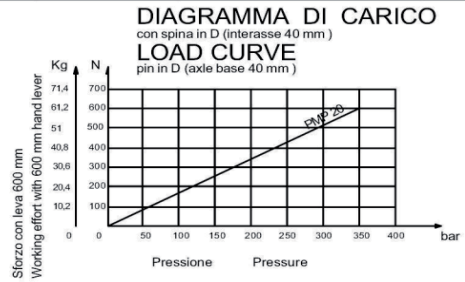
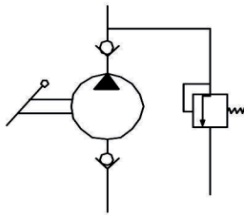

PMP 20 byB-e

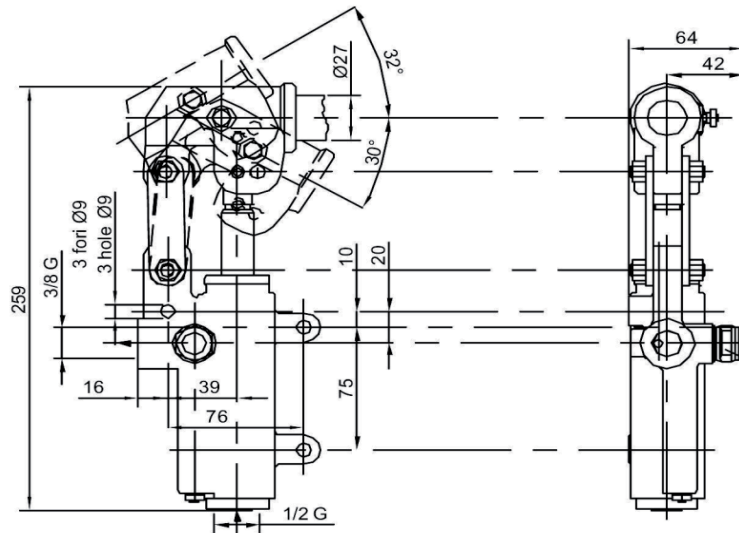

Valvola di massima pressione taratura standard 100 bar
(Pressure relief valve standard setting 100 bar)

PMP 20 byB-e-s

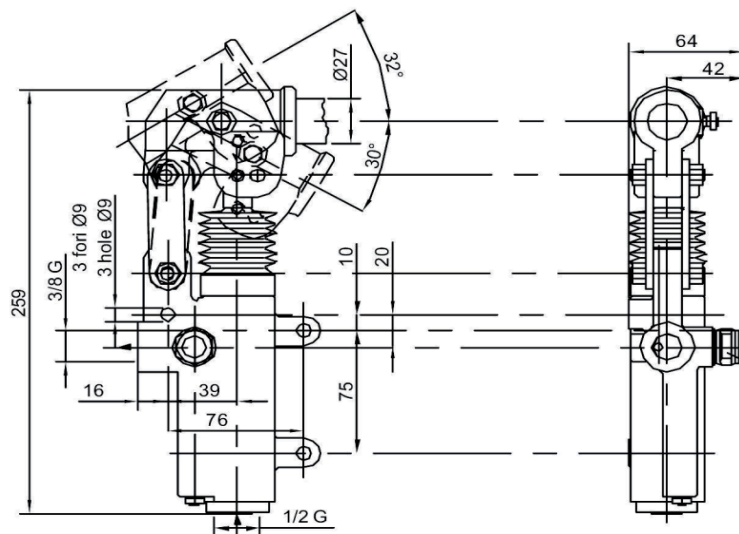

Valvola di massima pressione taratura standard 100 bar
(Pressure relief valve standard setting 100 bar)

POMPA A MANO HAND PUMP

TIPO
TYPE

PMO 50

POMPA A MANO PMO 50 con volantino di scarico	HAND PUMP PMO 50 with exhaust handwheel
Pompa doppio effetto per cilindro a semplice effetto per montaggio in piano	Double-acting pump for a single-acting cylinder for fixing to horizontal plane

Tipo di pompa Type of pump	Cilindr.(cm ³) Flow (cm ³)	Pressione (Pressure) (bar)		Massa (Kg) Weight (Kg)	Codice senza soffiet. Code without bellows	Codice con soffiet. Code with bellows
		eserciz.(exerciz.)	max.			
PMO 50	43,825	220	280	3,4	60770000	60770027

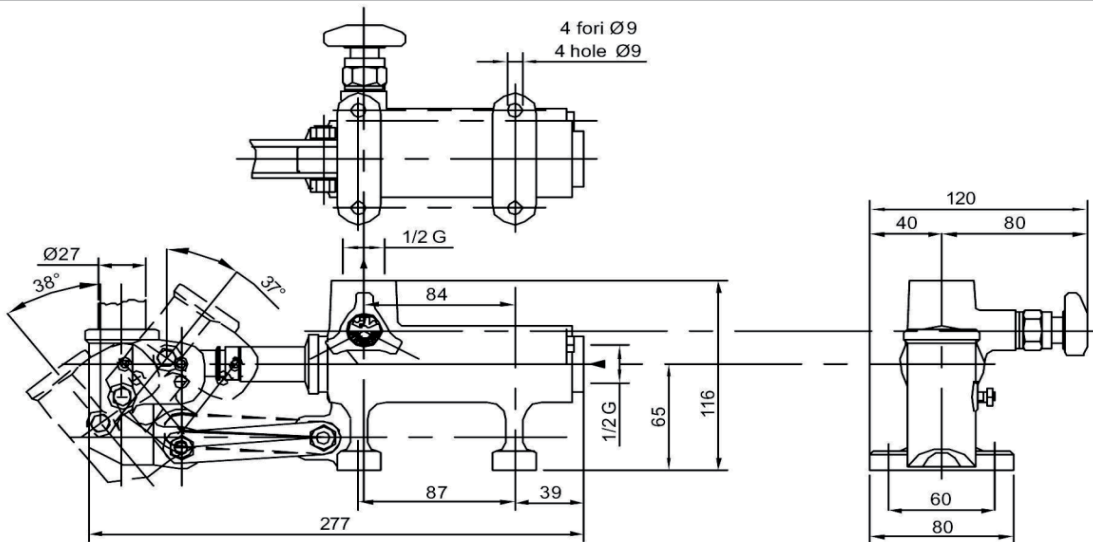
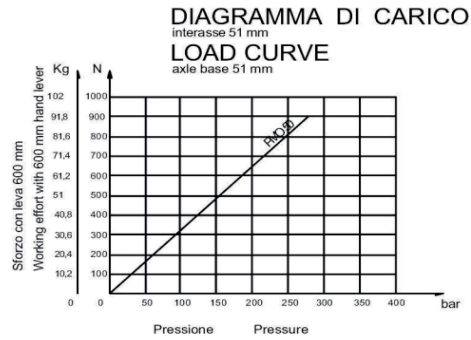
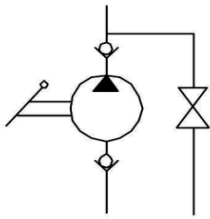

PMO 50

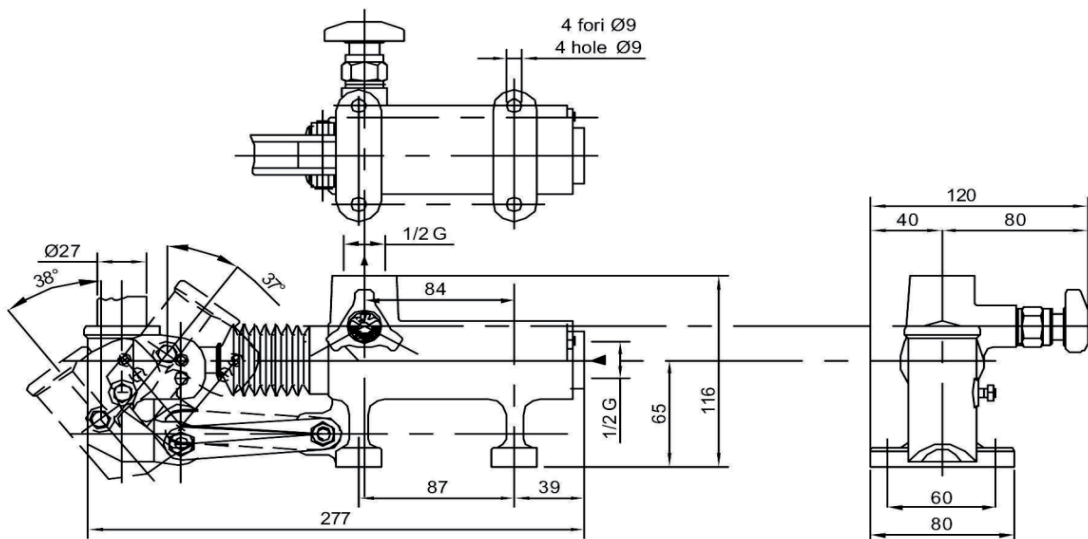

PMO 50 s

POMPA A MANO HAND PUMP

TIPO
TYPE

PMO 50

POMPA A MANO PMO 50 senza volantino di scarico	HAND PUMP PMO 50 without exhaust handwheel
Pompa doppio effetto per cilindro a semplice effetto per montaggio in piano	Double-acting pump for a single-acting cylinder for fixing to horizontal plane

Tipo di pompa Type of pump	Cilindr. (cm ³) Flow (cm ³)	Pressione (Pressure) (bar)		Massa (Kg) Weight (Kg)	Codice senza soffiet. Code without bellows	Codice con soffiet. Code with bellows
		eserciz. (exerciz.)	max.			
PMO 50	43,825	220	280	3,4	60770001	60770028

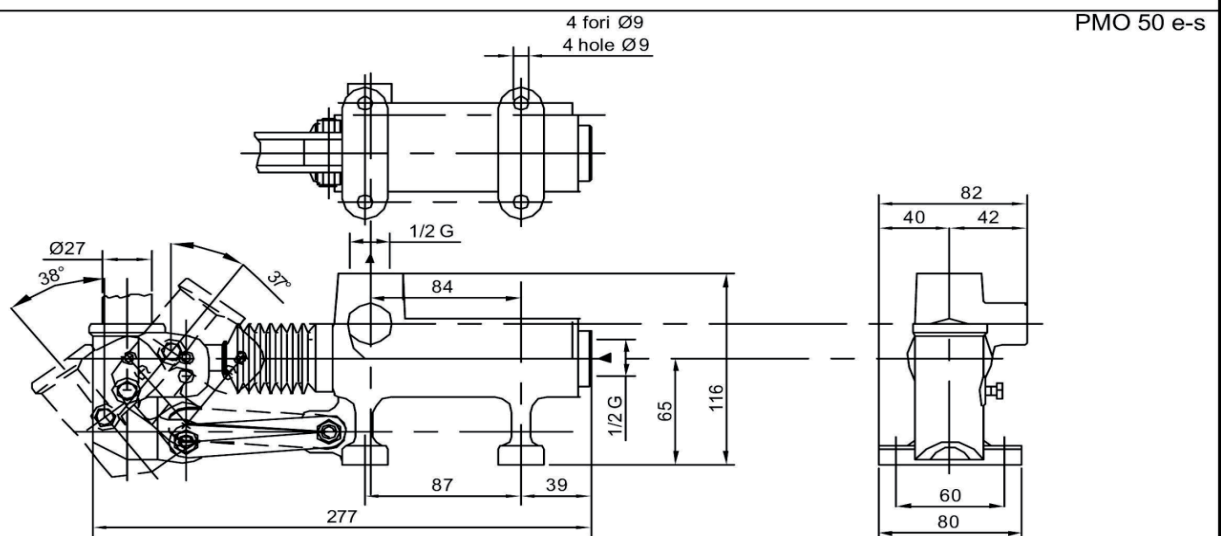
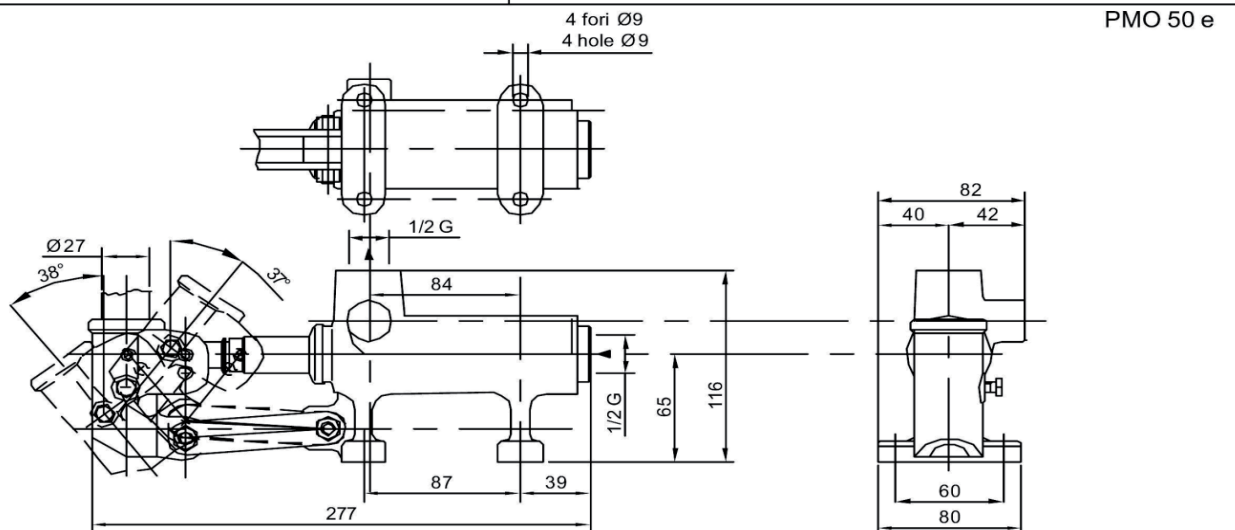
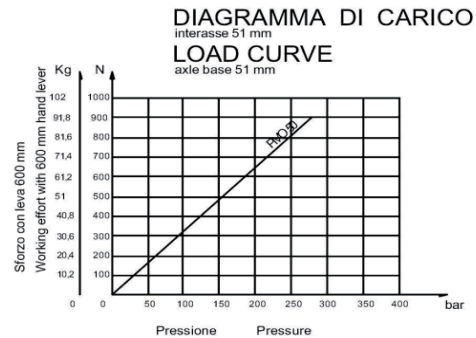
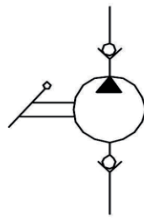

POMPA A MANO HAND PUMP

TIPO
TYPE

PMO 50

POMPA A MANO PMO 50 con manipolatore	HAND PUMP PMO 50 with release manipulator
Pompa doppio effetto per cilindro a semplice effetto per montaggio in piano	Double-acting pump for a single-acting cylinder for fixing to horizontal plane

Tipo di pompa Type of pump	Cilindr.(cm ³) Flow (cm ³)	Pressione (Pressure)(bar)		Massa (Kg) Weight(Kg)	Codice senza soffiet.	Codice con soffiet.
		eserciz.(exerciz.)	max.		Code without bellows	Code with bellows
PMO 50	43,825	220	280	3,4	60770002	60770029

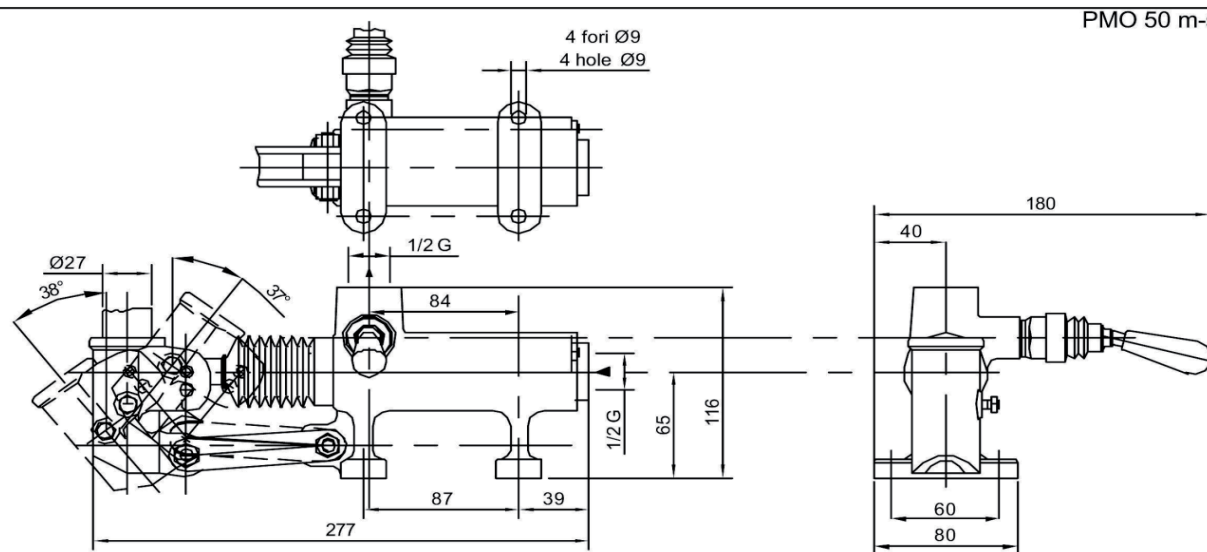
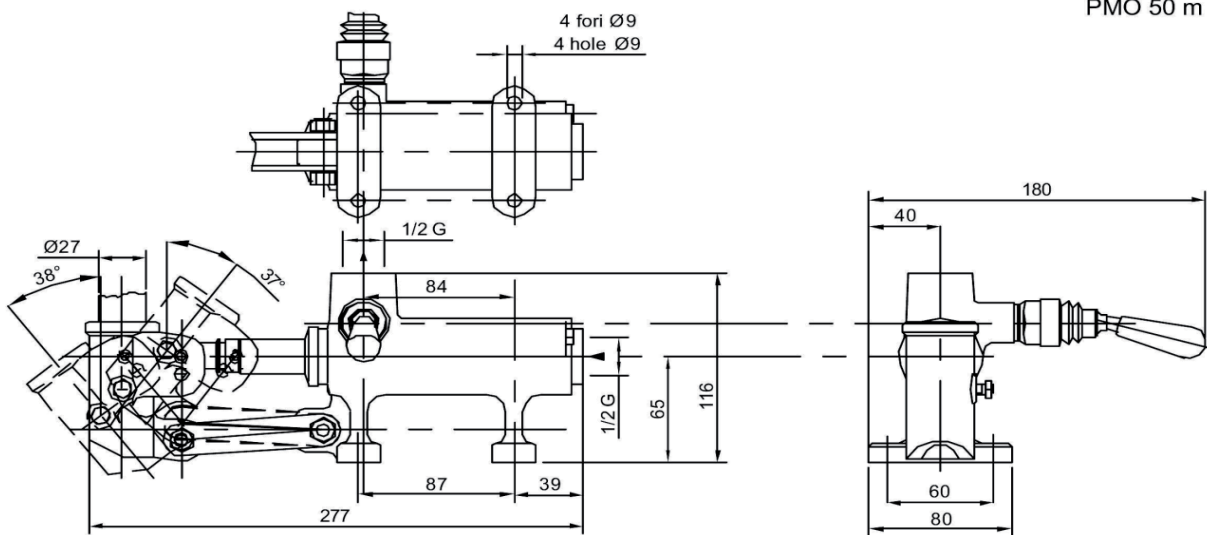
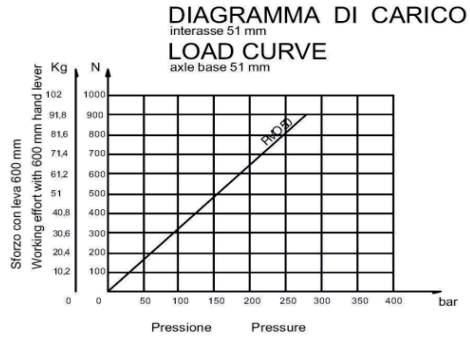
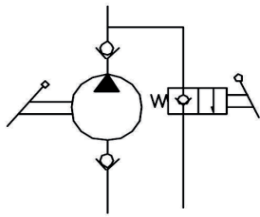

POMPA A MANO HAND PUMP

TIPO
TYPE

PMO 50

POMPA A MANO PMO 50 con leva di scarico	HAND PUMP PMO 50 with release lever
Pompa doppio effetto per cilindro a semplice effetto per montaggio in piano	Double-acting pump for a single-acting cylinder for fixing to horizontal plane

Tipo di pompa Type of pump	Cilindr.(cm ³) Flow (cm ³)	Pressione (Pressure)(bar)		Massa (Kg) Weight(Kg)	Codice senza soffiet. Code without bellows	Codice con soffiet. Code with bellows
		eserciz.(exerciz.)	max.			
PMO 50	43,825	220	280	3,4	60770003	60770030

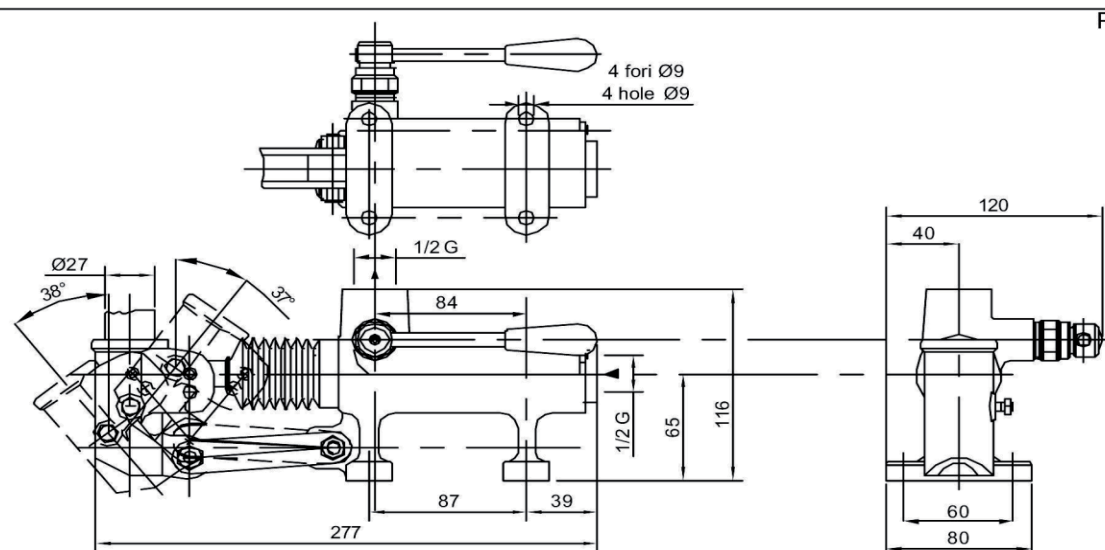
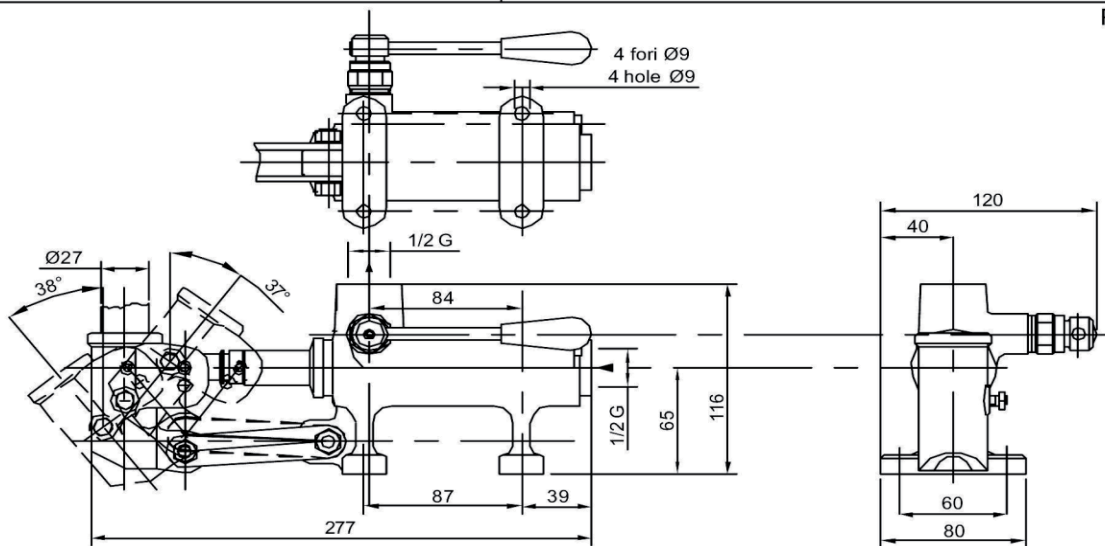
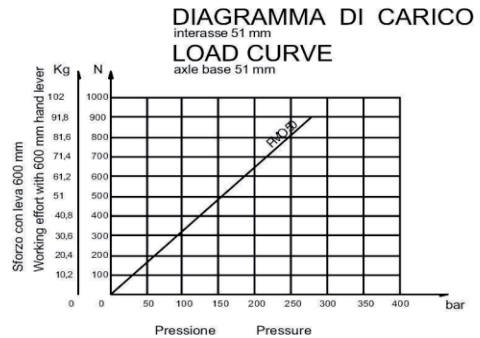
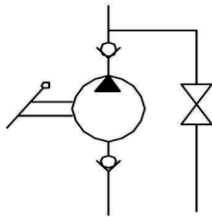

POMPA A MANO HAND PUMP

TIPO
TYPE

PMO 50

POMPA A MANO PMO 50 senza volantino di scarico con valvola di by-pass	HAND PUMP PMO 50 without exhaust handwheel with pressure relief valve
Pompa doppio effetto per cilindro a semplice effetto per montaggio in piano	Double-acting pump for a single-acting cylinder for fixing to horizontal plane

Tipo di pompa Type of pump	Cilindr. (cm ³) Flow (cm ³)	Pressione (Pressure) (bar)		Massa (Kg) Weight (Kg)	Codice senza soffiet. Code without bellows	Codice con soffiet. Code with bellows
		eserciz. (exerciz.)	max.			
PMO 50	43,825	220	280	3,4	60770004	60770031

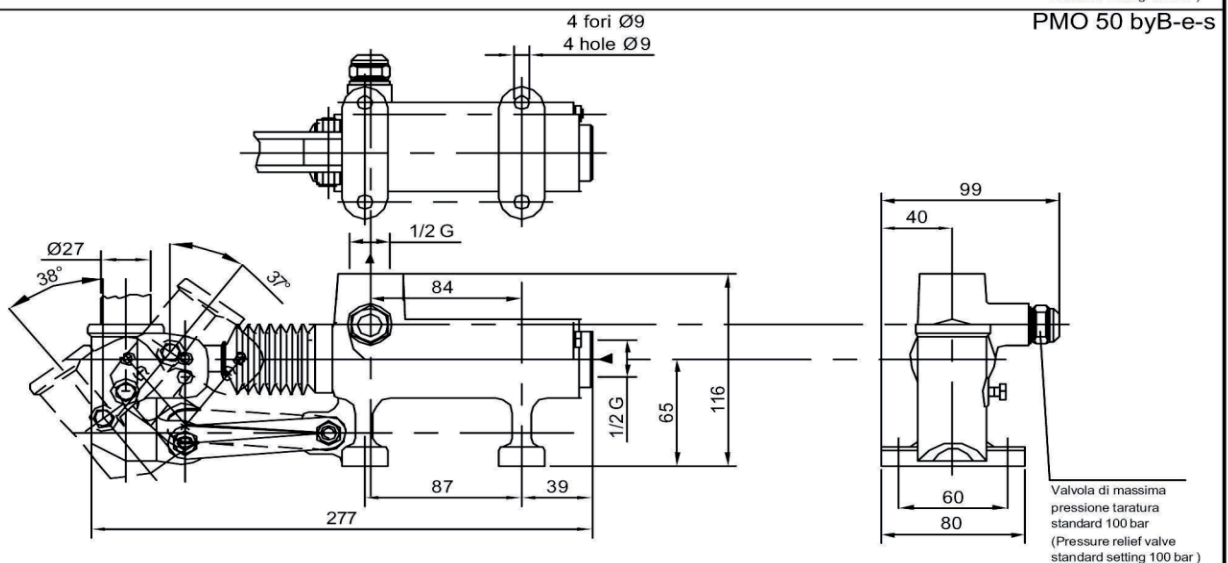
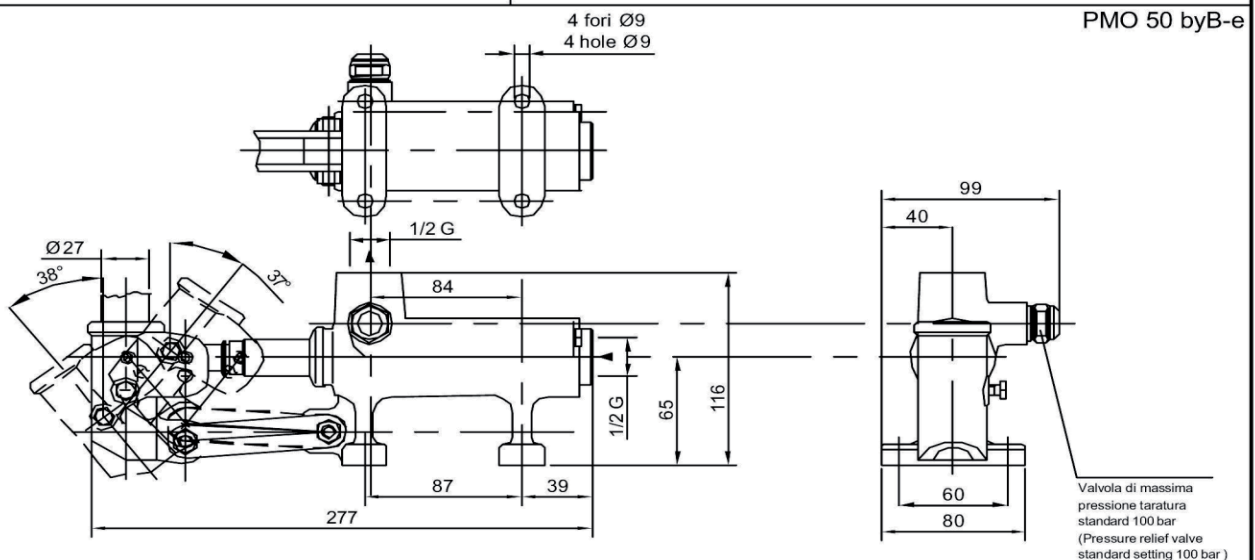
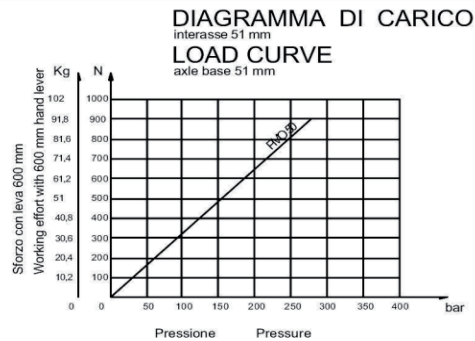
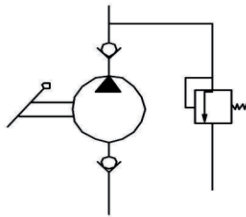

POMPA A MANO HAND PUMP

TIPO
TYPE

PMO 70

POMPA A MANO PMO 70 con volantino di scarico	HAND PUMP PMO 70 with exhaust handwheel
Pompa doppio effetto per cilindro a semplice effetto per montaggio in piano	Double-acting pump for a single-acting cylinder for fixing to horizontal plane

Tipo di pompa Type of pump	Cilindr.(cm ³) Flow (cm ³)	Pressione (Pressure)(bar)		Massa (Kg) Weight(Kg)	Codice senza soffiet. Code without bellows	Codice con soffiet. Code with bellows
		eserciz.(exerciz.)	max.			
PMO 70	70,233	180	230	5,1	60790000	60790027



DIAGRAMMA DI CARICO
interasse 51 mm
LOAD CURVE
axe base 51 mm



PMO 70

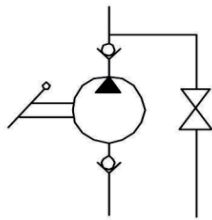
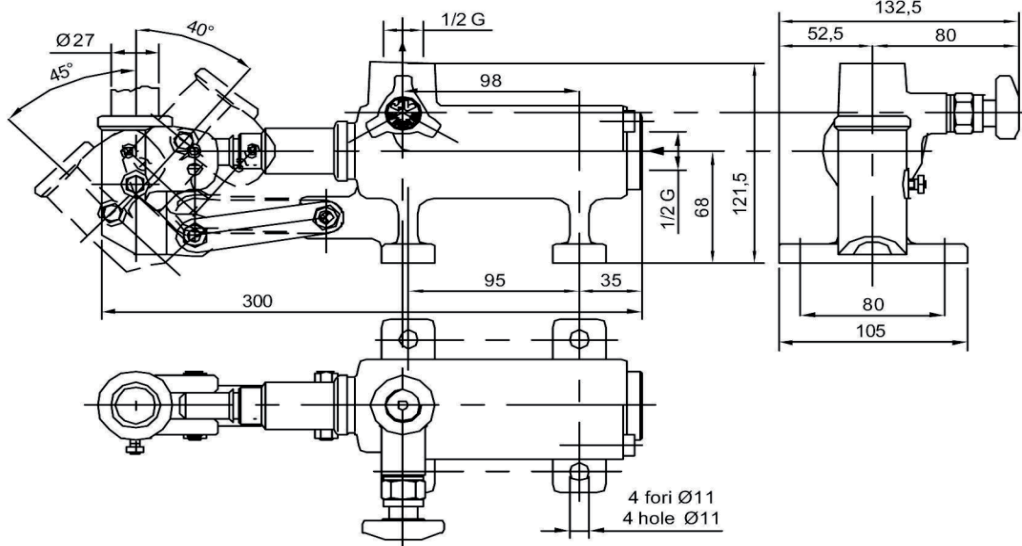
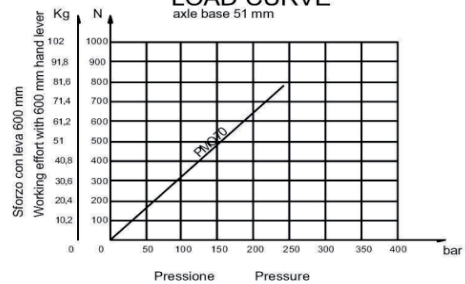
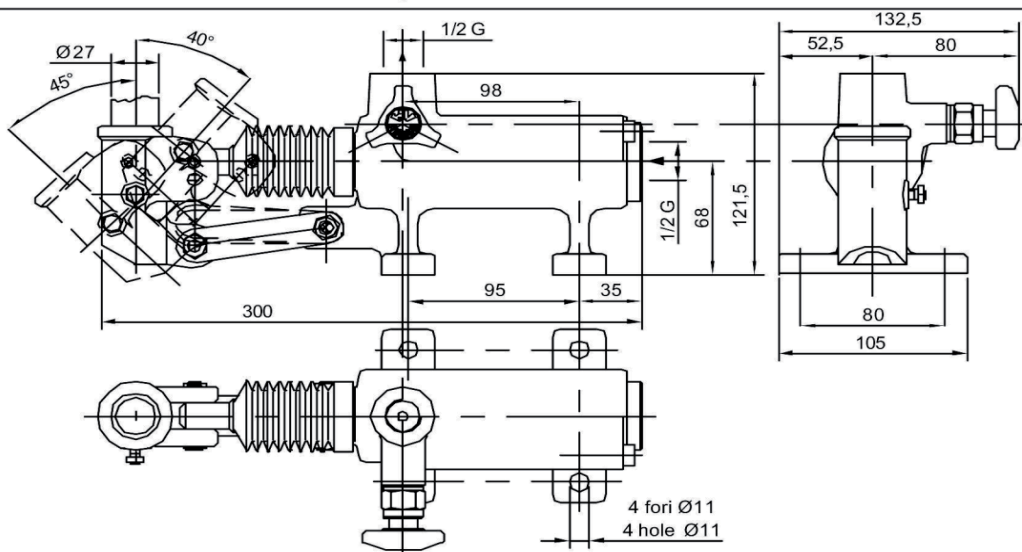

PMO 70 s

POMPA A MANO HAND PUMP

TIPO
TYPE

PMO 70

POMPA A MANO PMO 70 senza volantino di scarico	HAND PUMP PMO 70 without exhaust handwheel
Pompa doppio effetto per cilindro a semplice effetto per montaggio in piano	Double-acting pump for a single-acting cylinder for fixing to horizontal plane

Tipo di pompa Type of pump	Cilindr.(cm ³) Flow (cm ³)	Pressione (Pressure)(bar)		Massa (Kg) Weight(Kg)	Codice senza soffiet. Code without bellows	Codice con soffiet. Code with bellows
		eserciz.(exerciz.)	max.			
PMO 70	70,233	180	230	5,1	60790001	60790028



DIAGRAMMA DI CARICO
interasse 51 mm
LOAD CURVE
axle base 51 mm



PMO 70 e

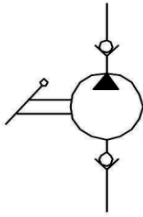
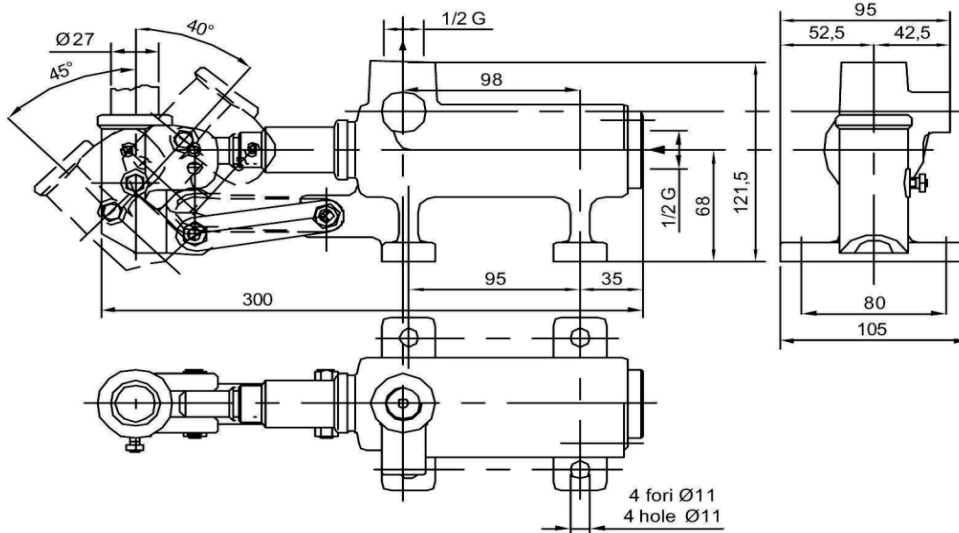
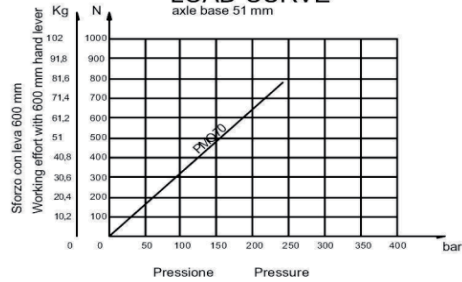
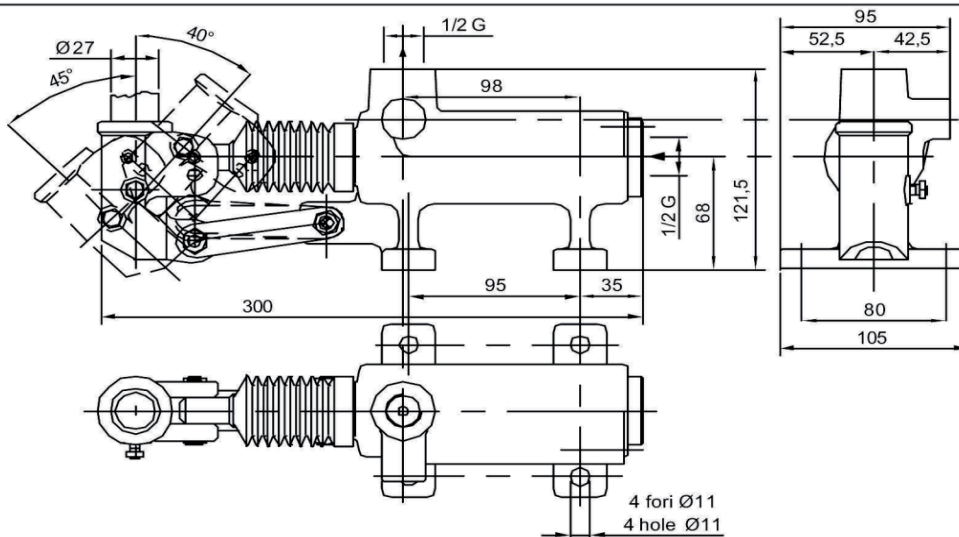

PMO 70 e-s

POMPA A MANO HAND PUMP

TIPO
TYPE

PMO 70

POMPA A MANO PMO 70 con manipolatore	HAND PUMP PMO 70 with release manipulator
Pompa doppio effetto per cilindro a semplice effetto per montaggio in piano	Double-acting pump for a single-acting cylinder for fixing to horizontal plane

Tipo di pompa Type of pump	Cilindr. (cm ³) Flow (cm ³)	Pressione (Pressure) (bar)		Massa (Kg) Weight (Kg)	Codice senza soffieta. Code without bellows	Codice con soffieta. Code with bellows
		eserciz. (exerciz.)	max.			
PMO 70	70,233	180	230	5,1	60790002	60790029



DIAGRAMMA DI CARICO

interasse 51 mm
LOAD CURVE
axle base 51 mm



PMO 70 m

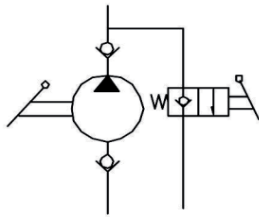
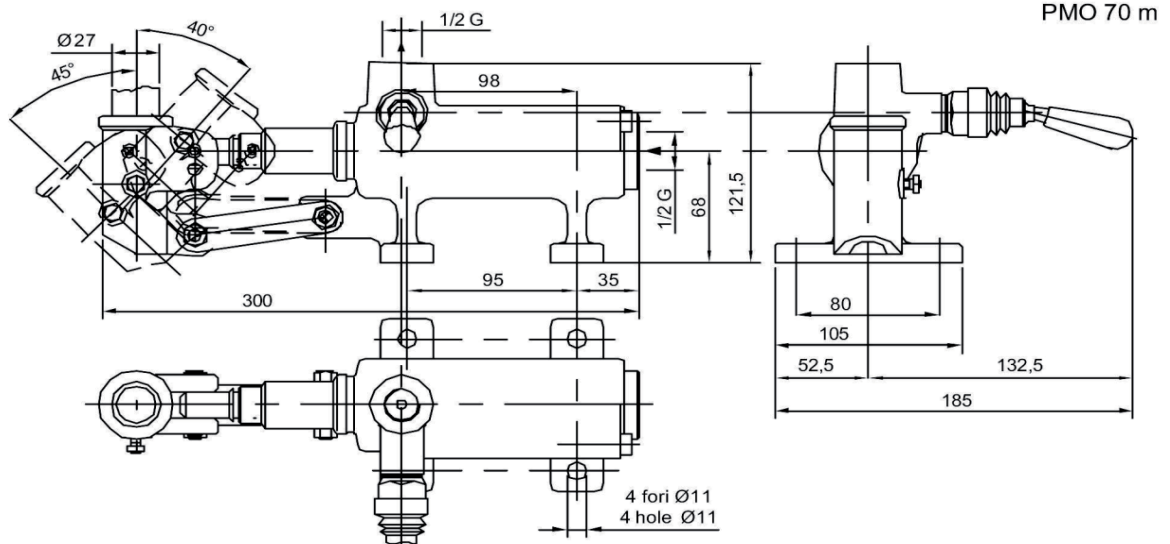
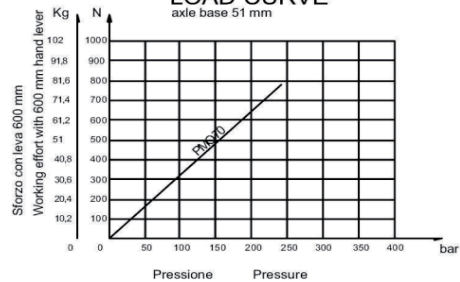
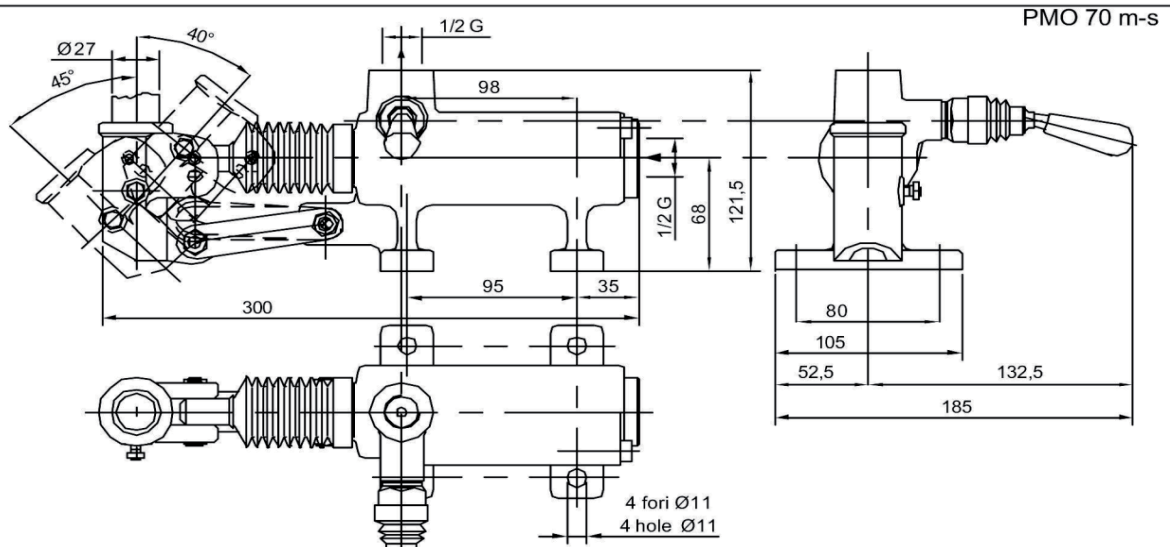

PMO 70 m-s

POMPA A MANO HAND PUMP

TIPO
TYPE

PMO 70

POMPA A MANO PMO 70 con leva di scarico	HAND PUMP PMO 70 with release lever
Pompa doppio effetto per cilindro a semplice effetto per montaggio in piano	Double-acting pump for a single-acting cylinder for fixing to horizontal plane

Tipo di pompa Type of pump	Cilindr.(cm ³) Flow (cm ³)	Pressione (Pressure) (bar)		Massa (Kg) Weight (Kg)	Codice senza soffiet. Code without bellows	Codice con soffiet. Code with bellows
		eserciz.(exerciz.)	max.			
PMO 70	70,233	180	230	5,1	60790003	60790030

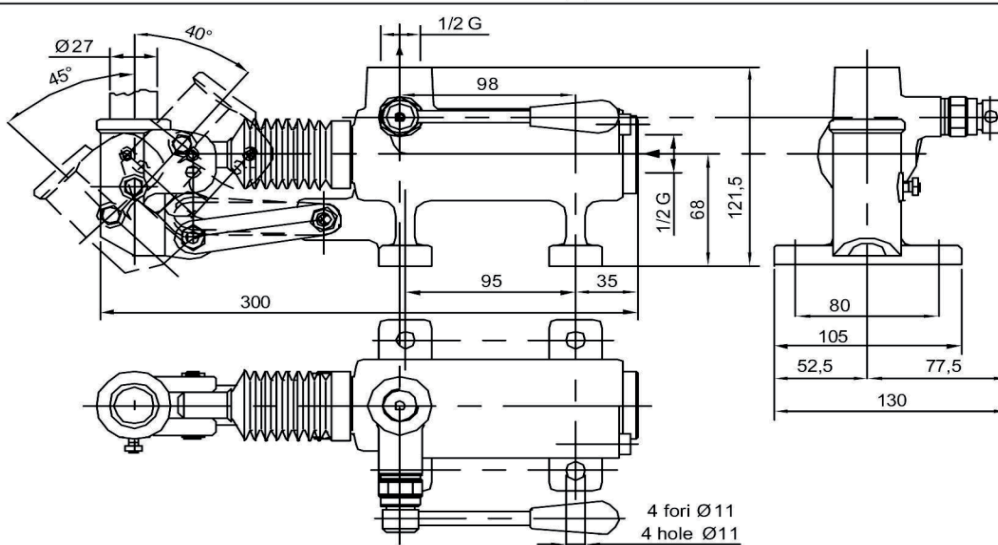
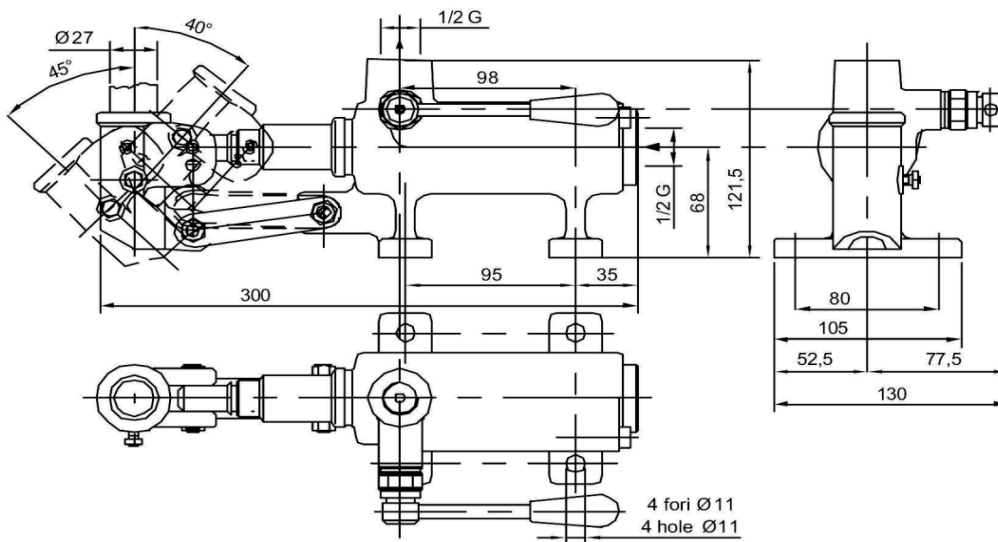
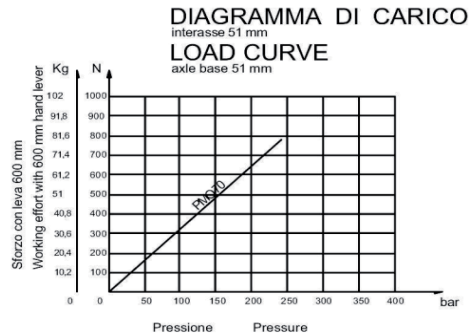
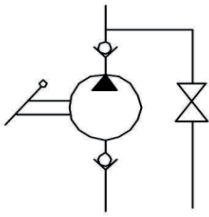

POMPA A MANO HAND PUMP

**TIPO
TYPE**

PMO 70

POMPA A MANO PMO 70 senza volantino di scarico con valvola di by-pass	HAND PUMP PMO 70 without exhaust handwheel with pressure relief valve
Pompa doppio effetto per cilindro a semplice effetto per montaggio in piano	Double-acting pump for a single-acting cylinder for fixing to horizontal plane

Tipo di pompa Type of pump	Cilindr.(cm ³) Flow (cm ³)	Pressione (Pressure)(bar)		Massa (Kg) Weight(Kg)	Codice senza soffiet. Code without bellows	Codice con soffiet. Code with bellows
		eserciz.(exerciz.)	max.			
PMO 70	70,233	180	230	5,1	60790004	60790031



DIAGRAMMA DI CARICO
interasse 51 mm
LOAD CURVE
axle base 51 mm



PMO 70 byB-e

Valvola di massima pressione taratura standard 100 bar
(Pressure relief valve standard setting 100 bar)

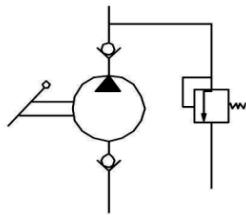
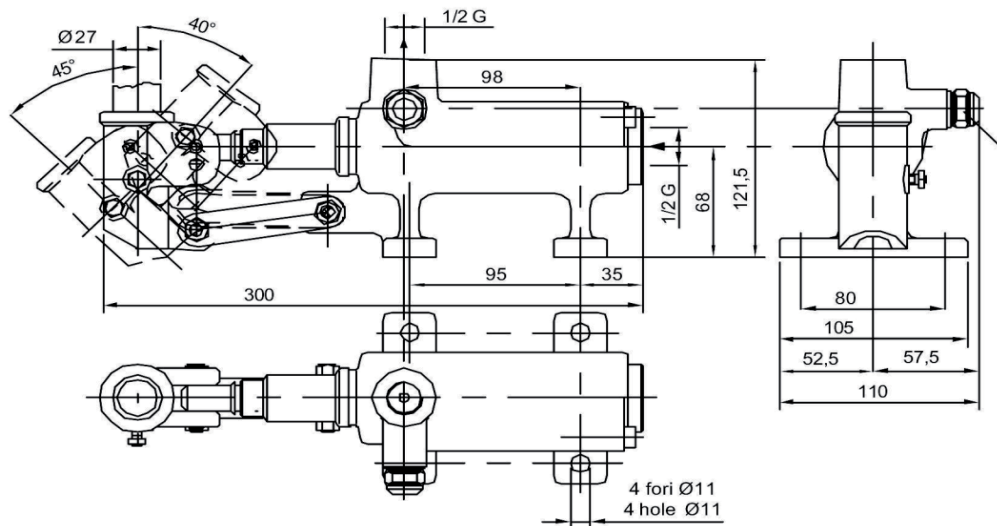
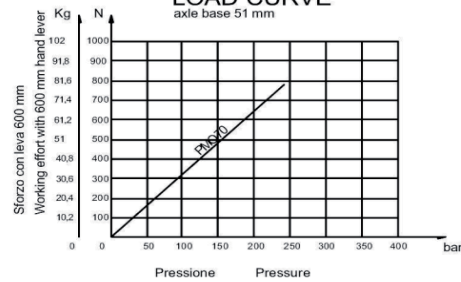
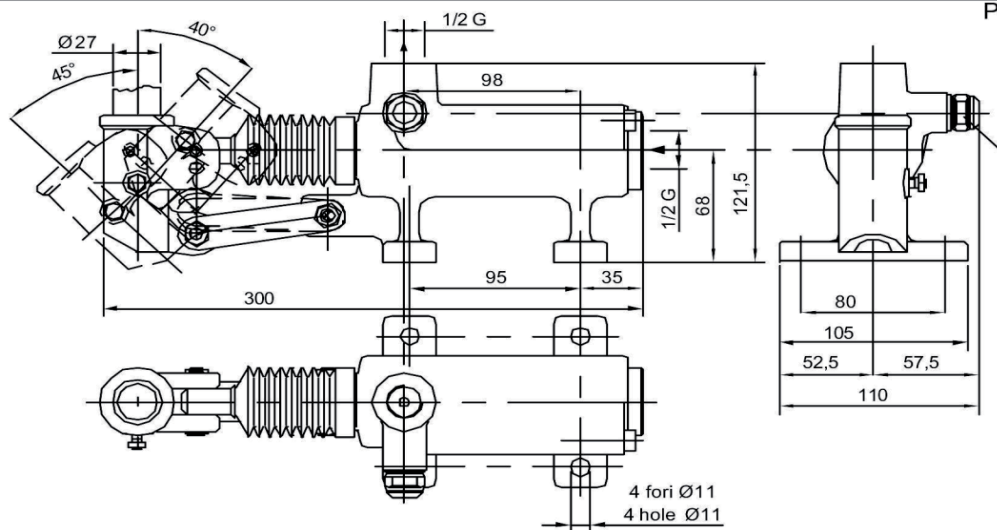

PMO 70 byB-e-s

Valvola di massima pressione taratura standard 100 bar
(Pressure relief valve standard setting 100 bar)

POMPA A MANO HAND PUMP

TIPO
TYPE

PM 12-25-45

POMPA A MANO PM 12-25-45 con volantino di scarico	HAND PUMP PM 12-25-45 with exhaust handwheel
Pompa doppio effetto per cilindro a semplice effetto per montaggio su serbatoio	Double-acting pump for single-acting cylinder for assembly on tank

Tipo di pompa Type of pump	Cilindr.(cm ³) Flow (cm ³)	Pressione (Pressure)(bar)		Massa (Kg) Weight(Kg)	Codice senza soffiet. Code without bellows	Codice con soffiet. Code with bellows
		eserciz.(exerciz.)	max.			
PM 12	12,095	320	380	2,90	60500000	60500027
PM 25	25,280	280	350	2,95	60510000	60510027
PM 45	44,532	220	280	3,00	60520000	60520027

TABELLA DIMENSIONI
SIZE TABLE

Tipo di pompa Type of pump	A (mm)	B (mm)	C (mm)	D (°)	E (°)
PM 12	253	166	34	26	31
PM 25	273	172	34	30	30
PM 45	283	172	40	45	33

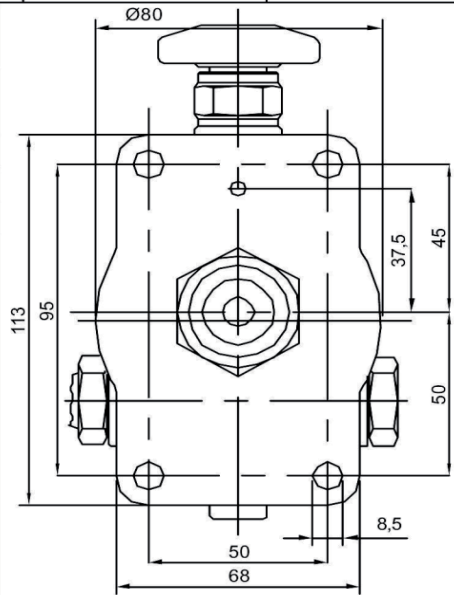
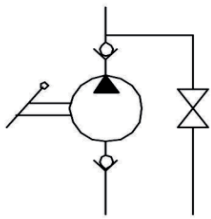

PM 12/25/45

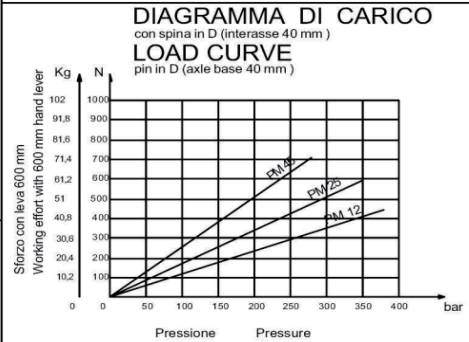
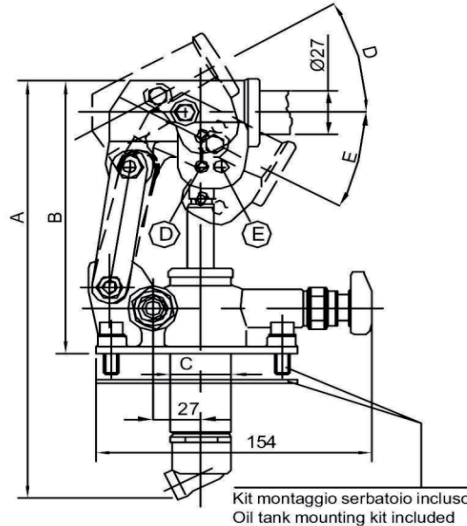
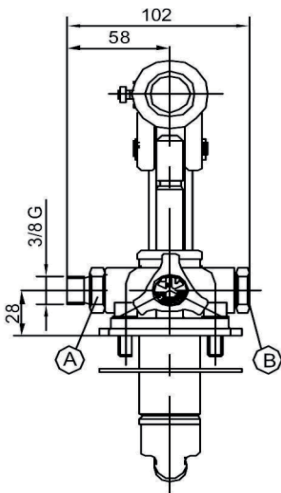

PM 12/25/45 s

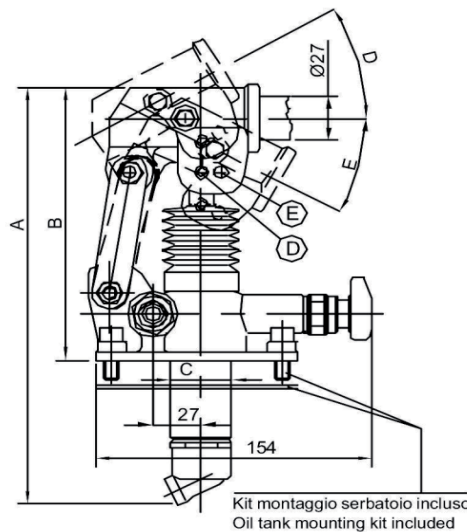
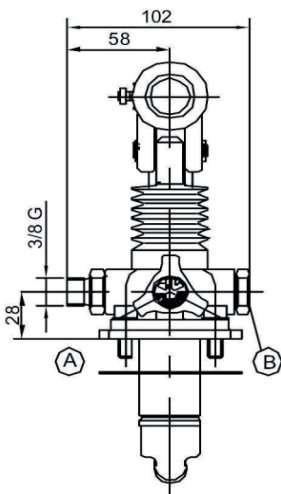

Interassi consigliati: PM 12 40 mm (D)
Axle base advised: PM 25 51 mm (E)
PM 45 51 mm (E)

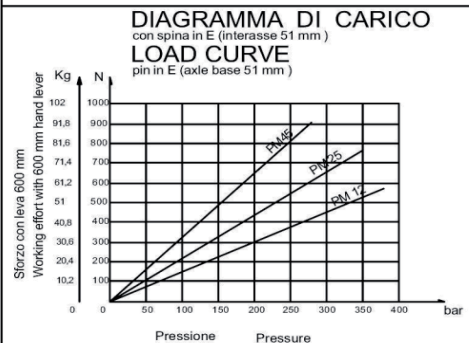

POMPA A MANO HAND PUMP

TIPO
TYPE

PM 12-25-45

POMPA A MANO PM 12-25-45 con volantino di scarico e valvola di by-pass	HAND PUMP PM 12-25-45 with exhaust handwheel and pressure relief valve
Pompa doppio effetto per cilindro a semplice effetto per montaggio su serbatoio	Double-acting pump for single-acting cylinder for assembly on tank

Tipo di pompa Type of pump	Cilindr. (cm ³) Flow (cm ³)	Pressione (Pressure) (bar)		Massa (Kg) Weight (Kg)	Codice senza soffiets. Code without bellows	Codice con soffiets. Code with bellows
		eserciz. (exerciz.)	max.			
PM 12	12,095	320	380	2,90	60500001	60500028
PM 25	25,280	280	350	2,95	60510001	60510028
PM 45	44,532	220	280	3,00	60520001	60520028

**TABELLA DIMENSIONI
SIZE TABLE**

Tipo di pompa Type of pump	A (mm)	B (mm)	C (mm)	D (°)	E (°)
PM 12	253	166	34	26	31
PM 25	273	172	34	30	30
PM 45	283	172	40	45	33

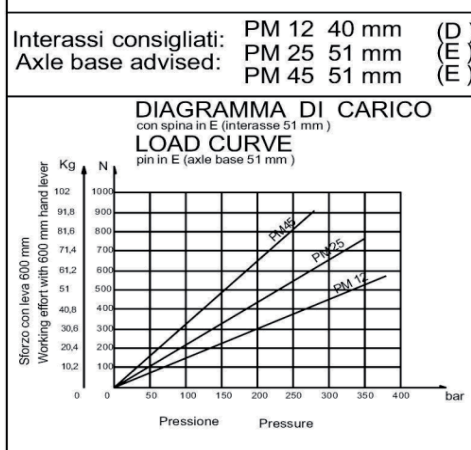
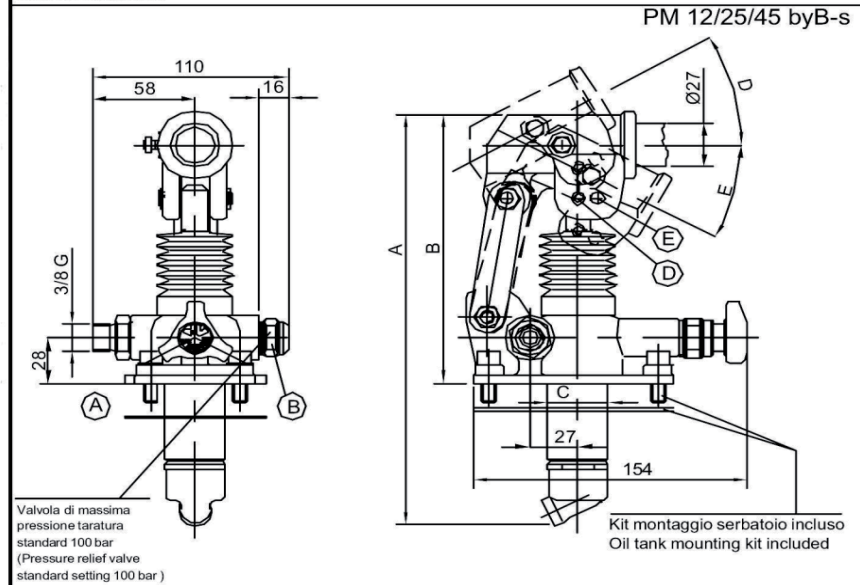
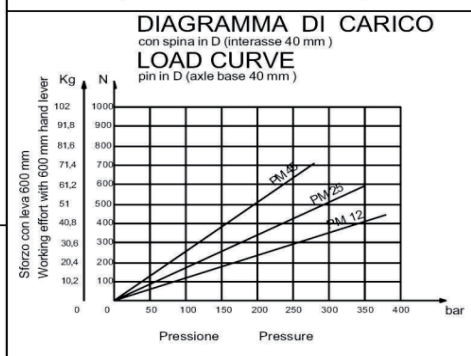
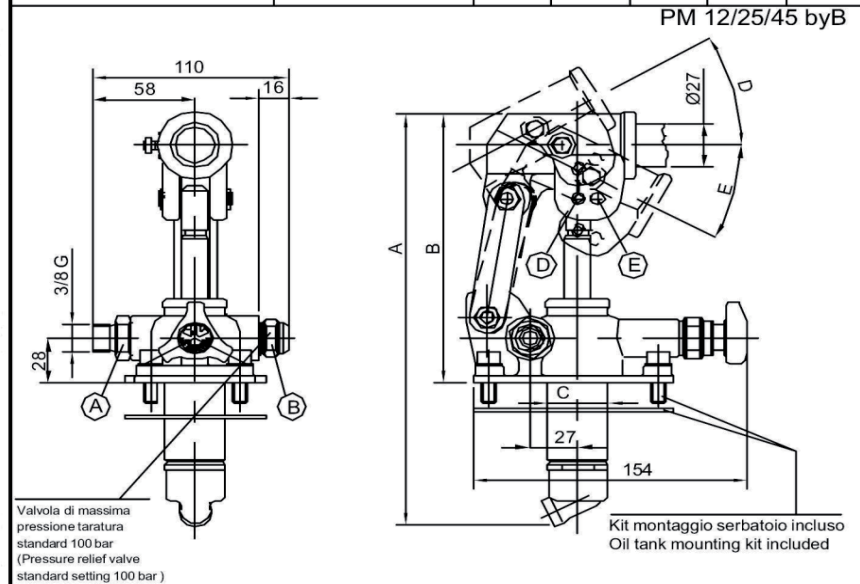
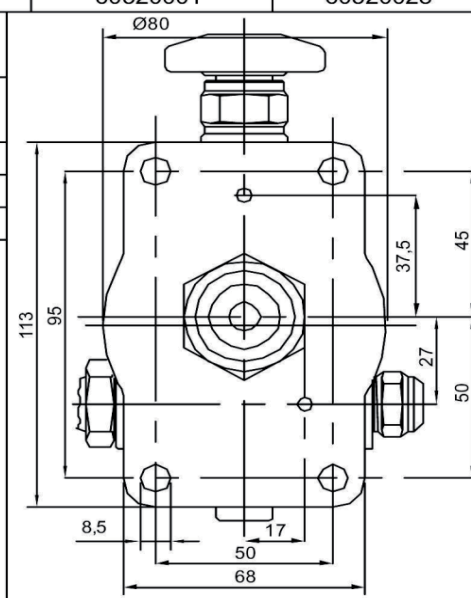

POMPA A MANO HAND PUMP

TIPO
TYPE

PM 12-25-45

POMPA A MANO PM 12-25-45 senza volantino di scarico	HAND PUMP PM 12-25-45 without exhaust wheel
Pompa doppio effetto per cilindro a semplice effetto per montaggio su serbatoio	Double-acting pump for single-acting cylinder for assembly on tank

Tipo di pompa Type of pump	Cilindr.(cm ³) Flow (cm ³)	Pressione (Pressure)(bar)		Massa (Kg) Weight(Kg)	Codice senza soffiet. Code without bellows	Codice con soffiet. Code with bellows
		eserciz.(exerciz.)	max.			
PM 12	12,095	320	380	2,90	60500002	60500029
PM 25	25,280	280	350	2,95	60510002	60510029
PM 45	44,532	220	280	3,00	60520002	60520029

TABELLA DIMENSIONI
SIZE TABLE

Tipo di pompa Type of pump	A (mm)	B (mm)	C (mm)	D (°)	E (°)
PM 12	253	166	34	26	31
PM 25	273	172	34	30	30
PM 45	283	172	40	45	33

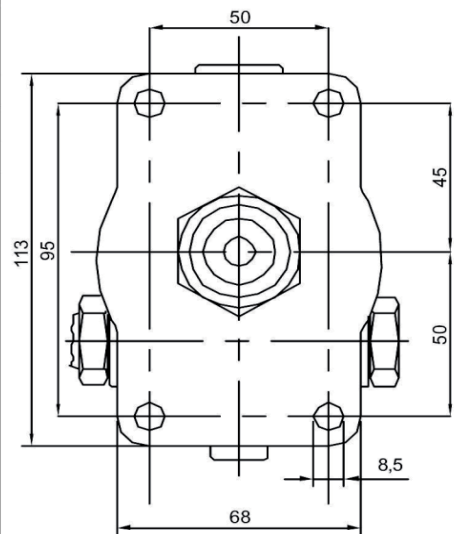
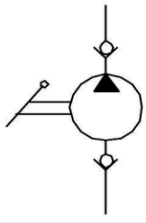

PM 12/25/45 e

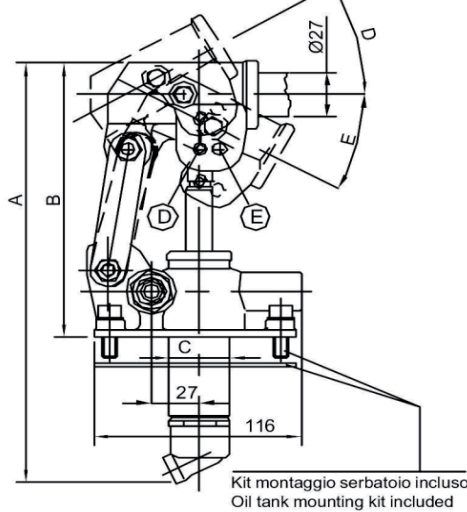
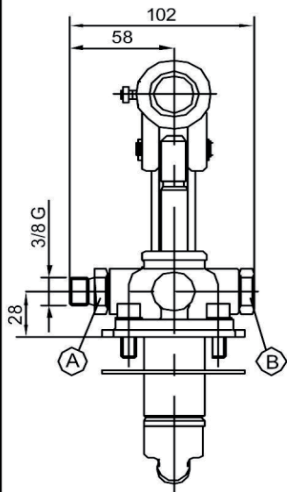

Kit montaggio serbatoio incluso
Oil tank mounting kit included

DIAGRAMMA DI CARICO
con spina in D (interasse 40 mm)
LOAD CURVE
pin in D (axle base 40 mm)

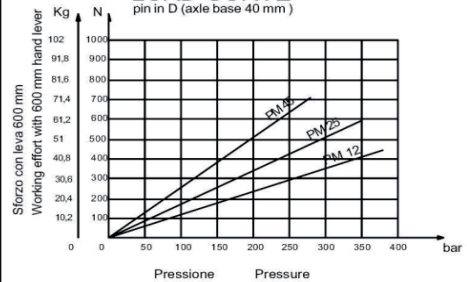

PM 12/25/45 e-s

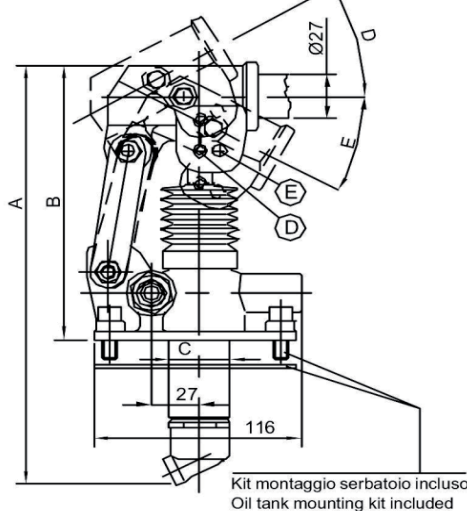
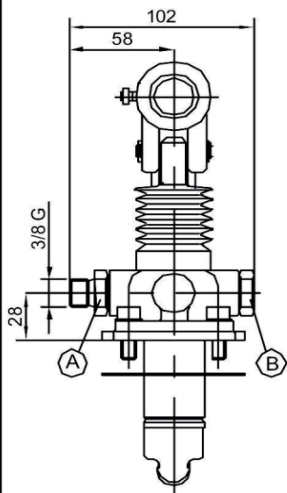

Kit montaggio serbatoio incluso
Oil tank mounting kit included

DIAGRAMMA DI CARICO
con spina in E (interasse 51 mm)
LOAD CURVE
pin in E (axle base 51 mm)

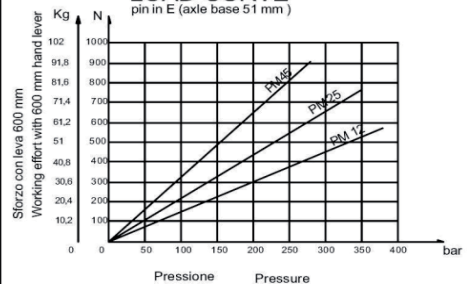

Interassi consigliati: PM 12 40 mm (D)
Axle base advised: PM 25 51 mm (E)
PM 45 51 mm (E)

POMPA A MANO HAND PUMP

TIPO TYPE

PM 12-25-45

POMPA A MANO PM 12-25-45
senza volantino di scarico con valvola di by-pass

HAND PUMP PM 12-25-45
without exhaust wheel with pressure relief valve

Pompa doppio effetto per cilindro a semplice effetto per montaggio su serbatoio

Double-acting pump for single-acting cylinder for assembly on tank

Tipo di pompa Type of pump	Cilindr.(cm ³) Flow (cm ³)	Pressione (Pressure)(bar)		Massa (Kg) Weight (Kg)	Codice senza soffiets. Code without bellows	Codice con soffiets. Code with bellows
		eserciz.(exerciz.)	max.			
PM 12	12,095	320	380	2,90	60500003	60500030
PM 25	25,280	280	350	2,95	60510003	60510030
PM 45	44,532	220	280	3,00	60520003	60520030

TABELLA DIMENSIONI
SIZE TABLE

Tipo di pompa Type of pump	A (mm)	B (mm)	C (mm)	D (°)	E (°)
PM 12	253	166	34	26	31
PM 25	273	172	34	30	30
PM 45	283	172	40	45	33

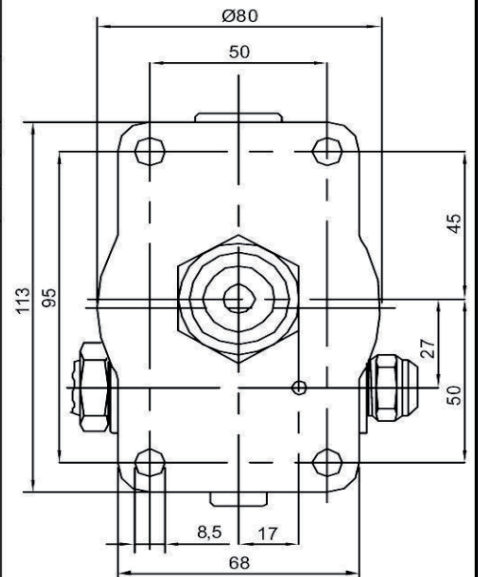
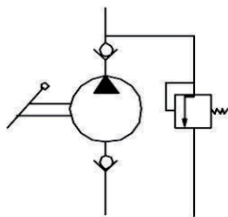

PM 12/25/45 byB-e

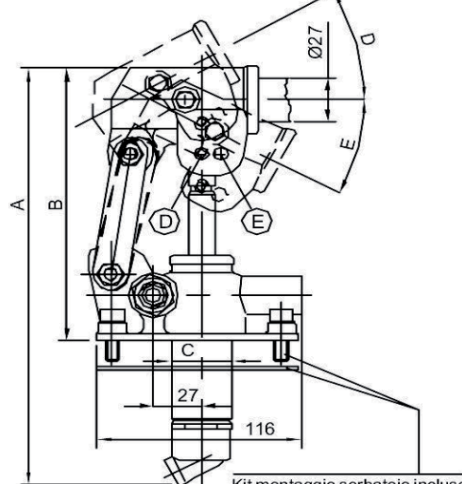
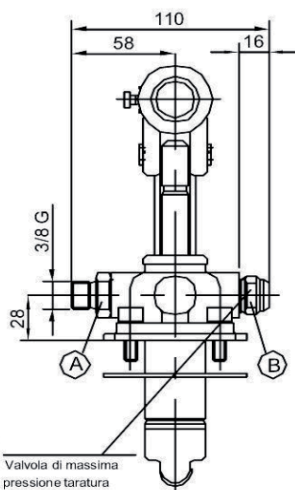

Valvola di massima pressione taratura standard 100 bar
(Pressure relief valve standard setting 100 bar)

Kit montaggio serbatoio incluso
Oil tank mounting kit included

DIAGRAMMA DI CARICO
con spina in D (interasse 40 mm)
LOAD CURVE
pin in D (axle base 40 mm)

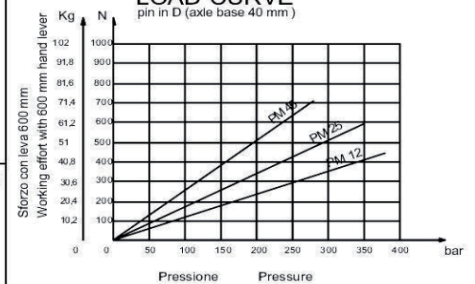

PM 12/25/45 byB-e-s

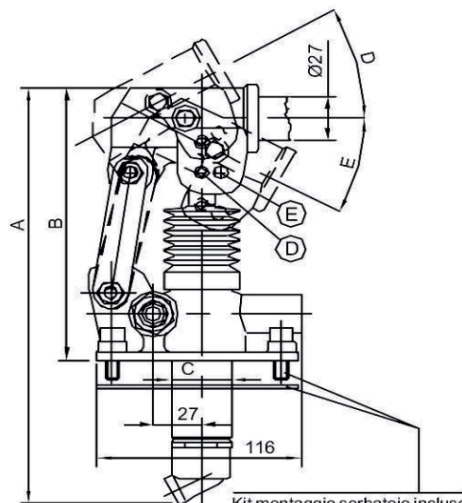
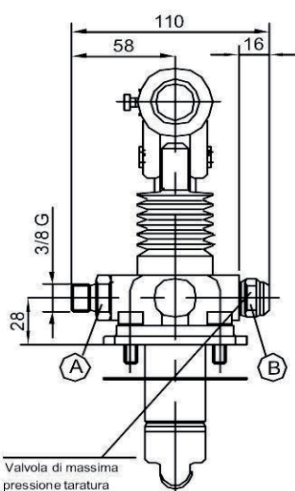

Valvola di massima pressione taratura standard 100 bar
(Pressure relief valve standard setting 100 bar)

Kit montaggio serbatoio incluso
Oil tank mounting kit included

DIAGRAMMA DI CARICO
con spina in E (interasse 51 mm)
LOAD CURVE
pin in E (axle base 51 mm)

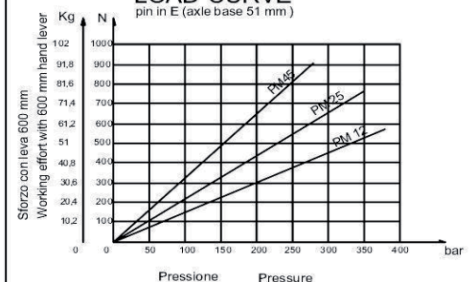

Interassi consigliati: PM 12 40 mm (D)
Axle base advised: PM 25 51 mm (E)
PM 45 51 mm (E)

POMPA A MANO HAND PUMP

TIPO
TYPE

PM 12-25-45

POMPA A MANO PM 12-25-45
con manipolatore

HAND PUMP PM 12-25-45
with release manipulator

Pompa doppio effetto per cilindro a semplice effetto per montaggio
su serbatoio

Double-acting pump for single-acting cylinder for assembly on tank

Tipo di pompa Type of pump	Cilindr.(cm ³) Flow (cm ³)	Pressione (Pressure)(bar)		Massa (Kg) Weight(Kg)	Codice senza soffiet. Code without bellows	Codice con soffiet. Code with bellows
		eserciz.(exerciz.)	max.			
PM 12	12,095	320	380	2,90	60500004	60500031
PM 25	25,280	280	350	2,95	60510004	60510031
PM 45	44,532	220	280	3,00	60520004	60520031

TABELLA DIMENSIONI
SIZE TABLE

Tipo di pompa Type of pump	A (mm)	B (mm)	C (mm)	D (°)	E (°)
PM 12	253	166	34	26	31
PM 25	273	172	34	30	30
PM 45	283	172	40	45	33

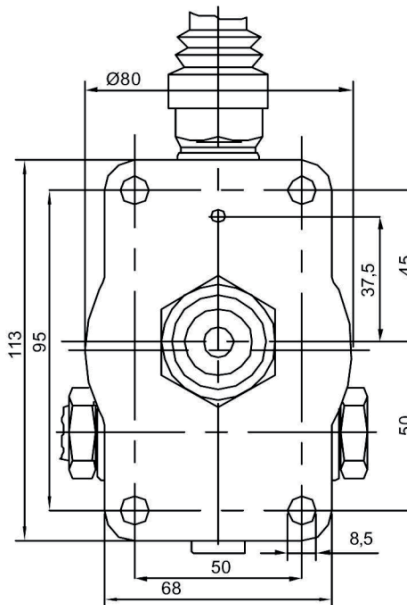

PM 12/25/45 m



DIAGRAMMA DI CARICO
con spina in D (interasse 40 mm)
LOAD CURVE
pin in D (axle base 40 mm)



Interassi consigliati: PM 12 40 mm (D)
Axle base advised: PM 25 51 mm (E)
PM 45 51 mm (E)

PM 12/25/45 m-s

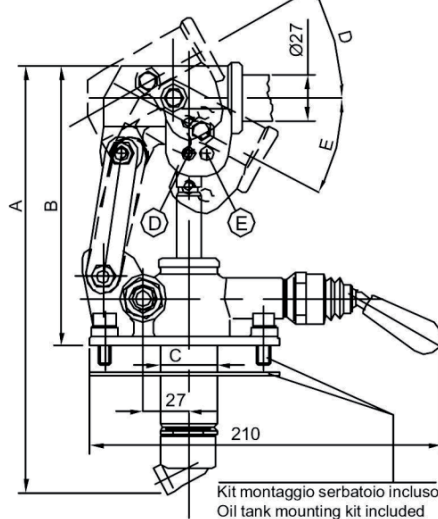
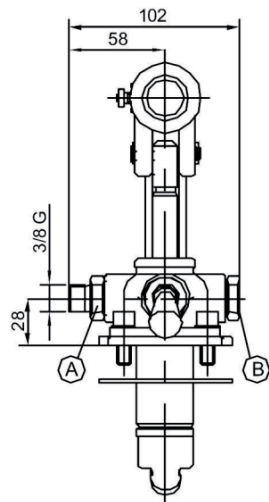
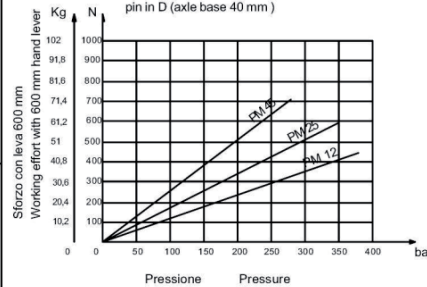

DIAGRAMMA DI CARICO
con spina in E (interasse 51 mm)
LOAD CURVE
pin in E (axle base 51 mm)



POMPA A MANO HAND PUMP

TIPO
TYPE

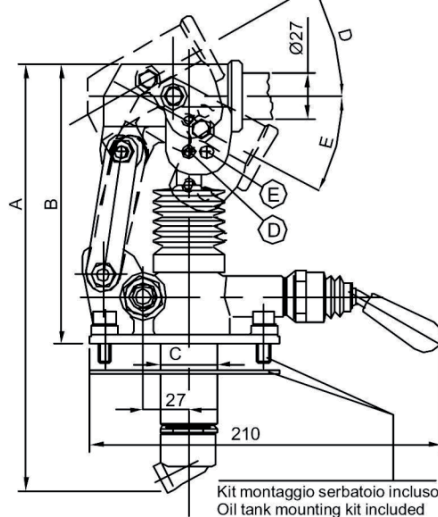
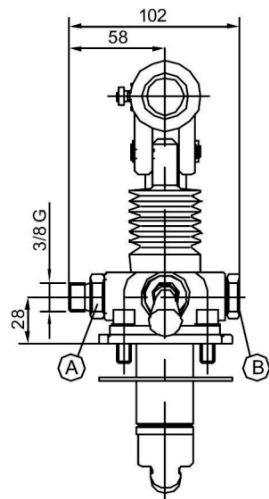
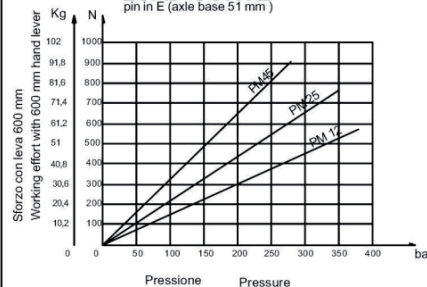
PM 12-25-45

POMPA A MANO PM 12-25-45
con manipolatore e valvola di by-pass

HAND PUMP PM 12-25-45
with release manipulator and pressure relief valve

Pompa doppio effetto per cilindro a semplice effetto per montaggio su serbatoio

Double-acting pump for single-acting cylinder for assembly on tank

Tipo di pompa Type of pump	Cilindr. (cm ³) Flow (cm ³)	Pressione (Pressure) (bar)		Massa (Kg) Weight (Kg)	Codice senza soffieta Code without bellows	Codice con soffieta Code with bellows
		eserciz. (exerciz.)	max.			
PM 12	12,095	320	380	2,90	60500005	60500032
PM 25	25,280	280	350	2,95	60510005	60510032
PM 45	44,532	220	280	3,00	60520005	60520032

TABELLA DIMENSIONI
SIZE TABLE

Tipo di pompa Type of pump	A (mm)	B (mm)	C (mm)	D (°)	E (°)
PM 12	253	166	34	26	31
PM 25	273	172	34	30	30
PM 45	283	172	40	45	33

PM 12/25/45 byB-m

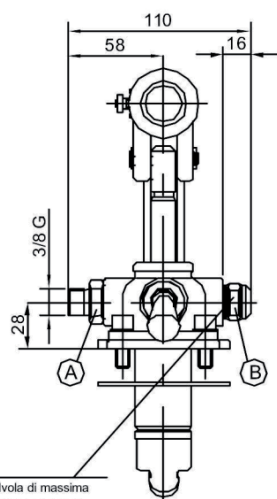
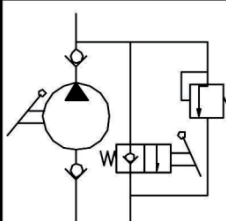

Valvola di massima pressione taratura standard 100 bar
(Pressure relief valve standard setting 100 bar)

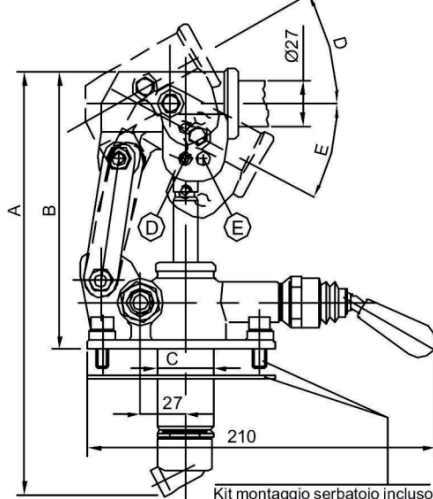

Kit montaggio serbatoio incluso
Oil tank mounting kit included



DIAGRAMMA DI CARICO
con spina in D (interasse 40 mm)
LOAD CURVE
pin in D (axle base 40 mm)



PM 12/25/45 byB-m-s

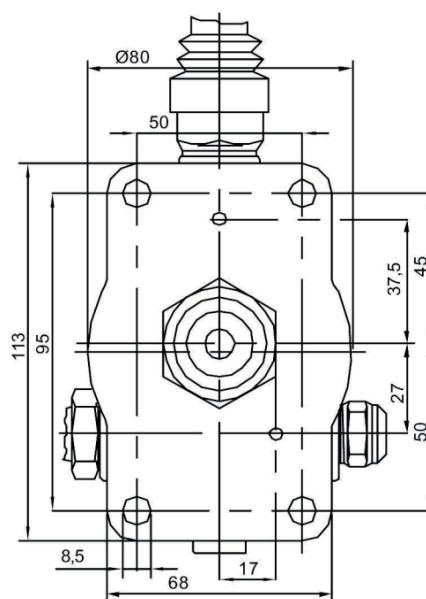
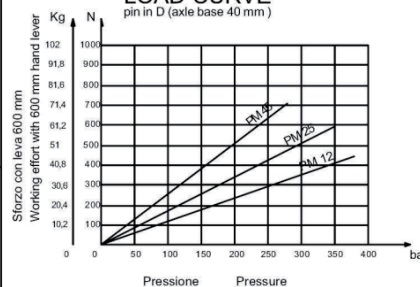
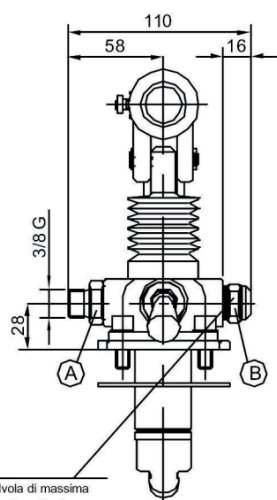

Valvola di massima pressione taratura standard 100 bar
(Pressure relief valve standard setting 100 bar)

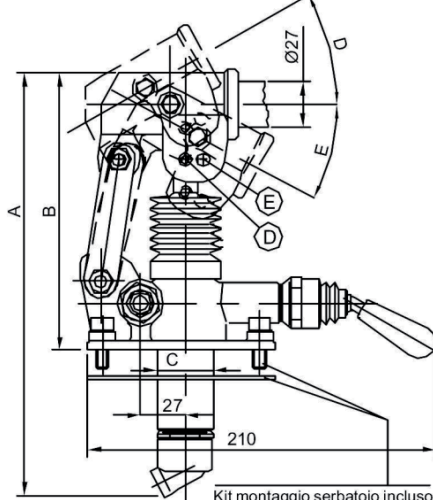

Kit montaggio serbatoio incluso
Oil tank mounting kit included

DIAGRAMMA DI CARICO
con spina in E (interasse 51 mm)
LOAD CURVE
pin in E (axle base 51 mm)

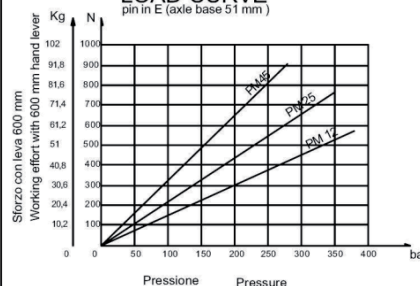

Interassi consigliati: PM 12 40 mm (D)
Axle base advised: PM 25 51 mm (E)
PM 45 51 mm (E)

POMPA A MANO HAND PUMP

TIPO
TYPE

PM 12-25-45

POMPA A MANO PM 12-25-45 con leva di scarico	HAND PUMP PM 12-25-45 with exhaust lever
Pompa doppio effetto per cilindro a semplice effetto per montaggio su serbatoio	Double-acting pump for single-acting cylinder for assembly on tank

Tipo di pompa Type of pump	Cilindr.(cm ³) Flow (cm ³)	Pressione (Pressure)(bar)		Massa (Kg) Weight(Kg)	Codice senza soffieta. Code without bellows	Codice con soffieta. Code with bellows
		eserciz.(exerciz.)	max.			
PM 12	12,095	320	380	2,90	60500006	60500033
PM 25	25,280	280	350	2,95	60510006	60510033
PM 45	44,532	220	280	3,00	60520006	60520033

TABELLA DIMENSIONI
SIZE TABLE

Tipo di pompa Type of pump	A (mm)	B (mm)	C (mm)	D (°)	E (°)
PM 12	253	166	34	26	31
PM 25	273	172	34	30	30
PM 45	283	172	40	45	33

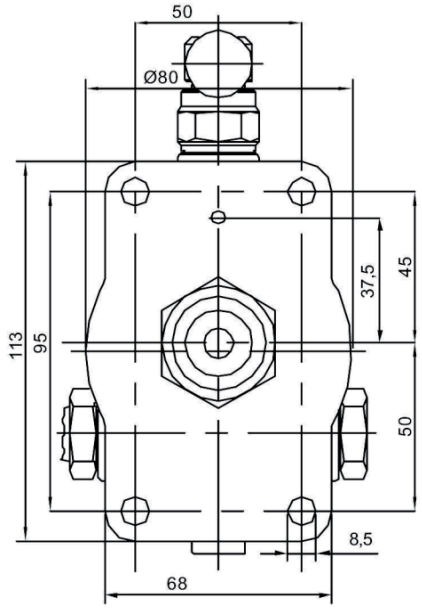
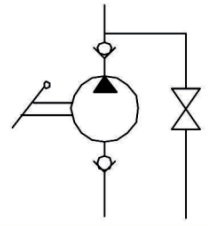

PM 12/25/45 L

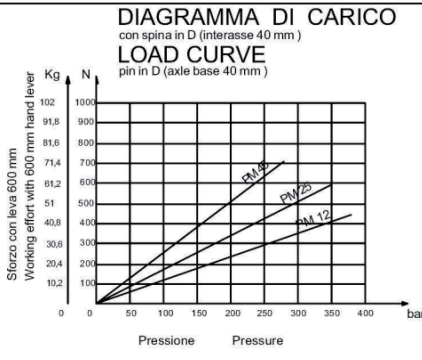
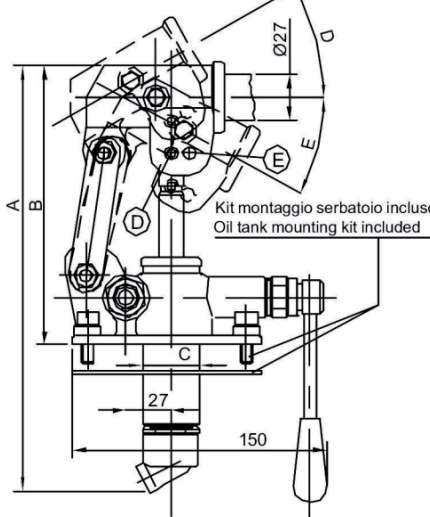
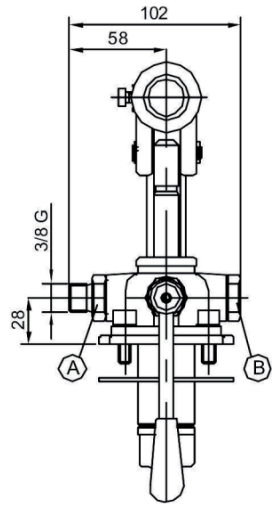

PM 12/25/45 L-s

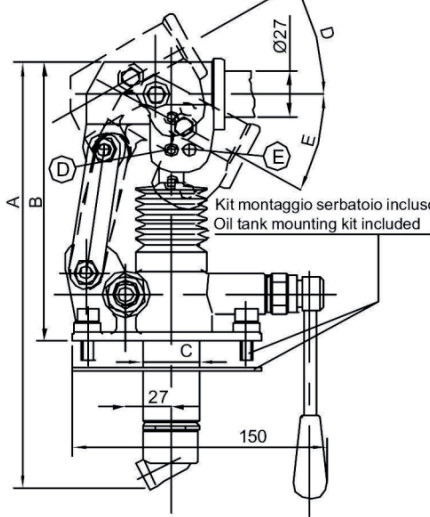
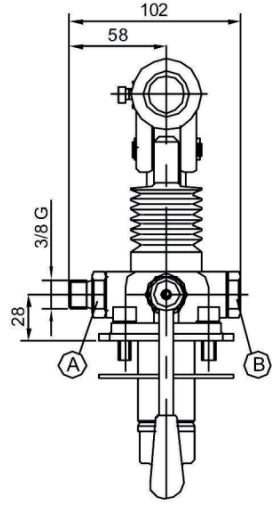

Interassi consigliati: PM 12 40 mm (D)
Axle base advised: PM 25 51 mm (E)
PM 45 51 mm (E)

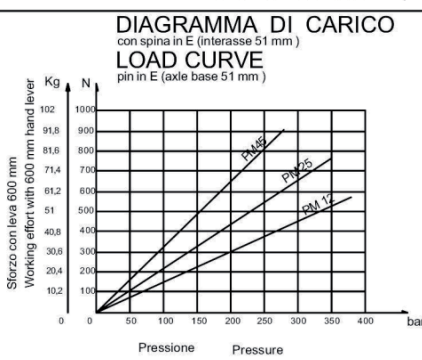

POMPA A MANO HAND PUMP

TIPO
TYPE

PM 12-25-45

POMPA A MANO PM 12-25-45 con leva di scarico e valvola di by-pass	HAND PUMP PM 12-25-45 with exhaust lever and pressure relief valve
Pompa doppio effetto per cilindro a semplice effetto per montaggio su serbatoio	Double-acting pump for single-acting cylinder for assembly on tank

Tipo di pompa Type of pump	Cilindr. (cm ³) Flow (cm ³)	Pressione (Pressure) (bar)		Massa (Kg) Weight (Kg)	Codice senza soffietti Code without bellows	Codice con soffietti Code with bellows
		eserciz. (exerciz.)	max.			
PM 12	12,095	320	380	2,90	60500007	60500034
PM 25	25,280	280	350	2,95	60510007	60510034
PM 45	44,532	220	280	3,00	60520007	60520034

Tipo di pompa Type of pump	A (mm)	B (mm)	C (mm)	D (°)	E (°)
PM 12	253	166	34	26	31
PM 25	273	172	34	30	30
PM 45	283	172	40	45	33

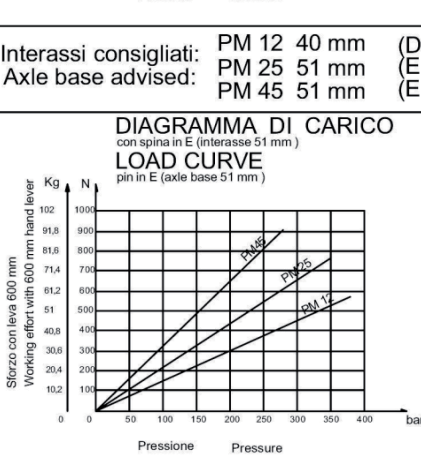
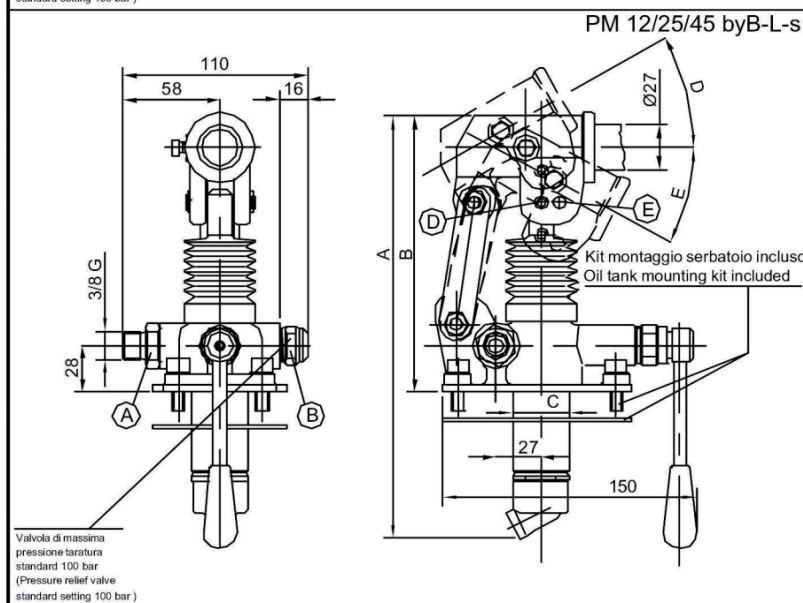
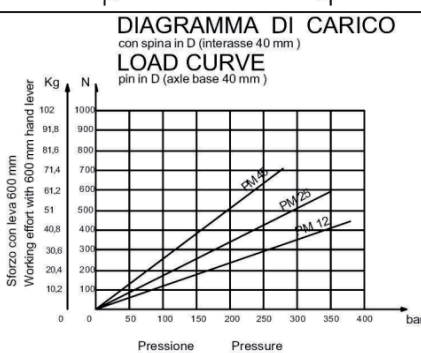
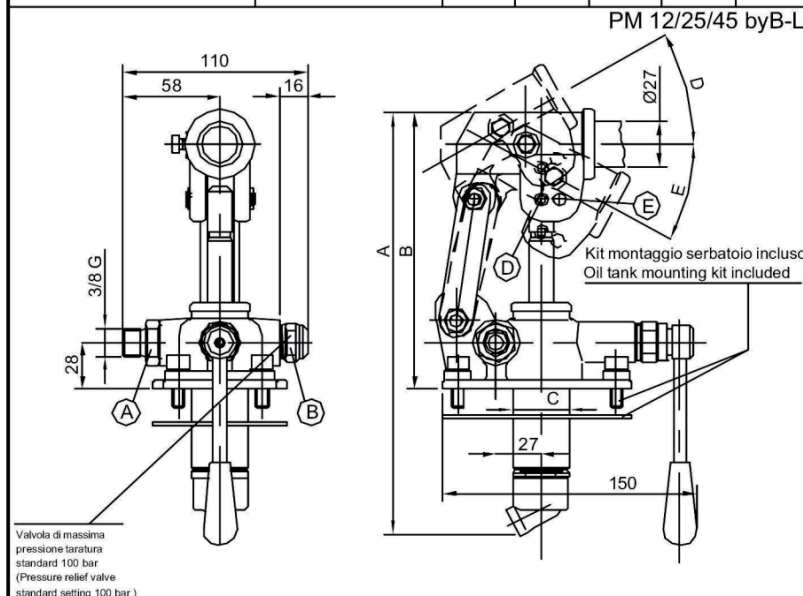
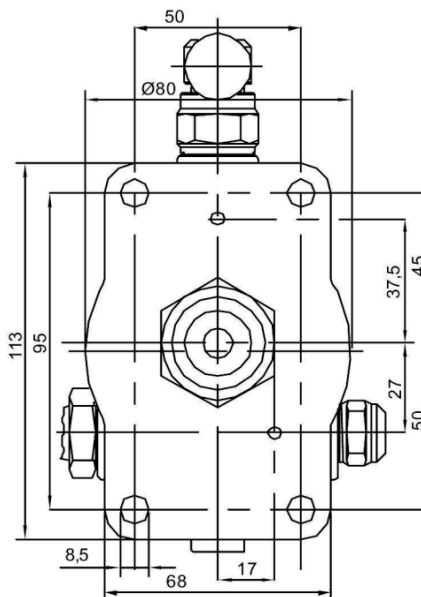

Interassi consigliati: PM 12 40 mm (D)
Axle base advised: PM 25 51 mm (E)
PM 45 51 mm (E)

POMPA A MANO HAND PUMP

TIPO
TYPE

PMD 12-25-45

POMPA A MANO PMD 12-25-45 con distributore 4/3	HAND PUMP PMD 12-25-45 with 4/3 diverter
Pompa doppio effetto con distributore 4/3 per cilindro a doppio effetto per montaggio su serbatoio	Double-acting pump with 4/3 diverter for double-acting cylinder for assembly on tank

Tipo di pompa Type of pump	Cilindr. (cm ³) Flow (cm ³)	Pressione (Pressure) (bar)		Massa (Kg) Weight (Kg)	Codice senza soffiet. Code without bellows	Codice con soffiet. Code with bellows
		eserciz. (exerciz.)	max.			
PMD 12	12,095	320	380	3,40	60550000	60550027
PMD 25	25,280	280	350	3,45	60560000	60560027
PMD 45	44,532	220	280	3,50	60570000	60570027



TABELLA DIMENSIONI SIZE TABLE					
Tipo di pompa Type of pump	A (mm)	B (mm)	C (mm)	D (°)	E (°)
PMD 12	253	166	34	26	31
PMD 25	273	172	34	30	30
PMD 45	283	172	40	45	33



PMD 12/25/45

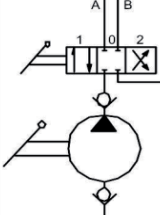
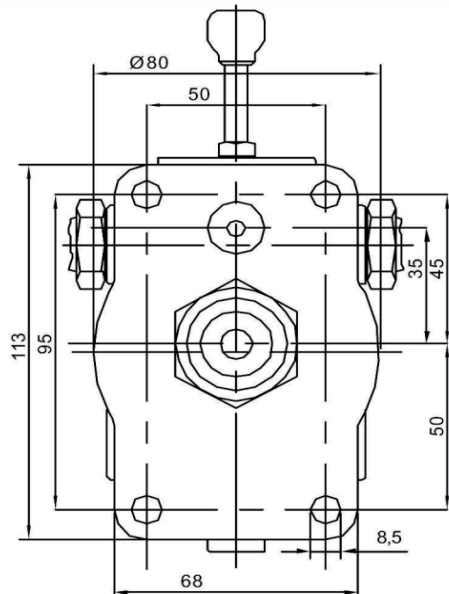
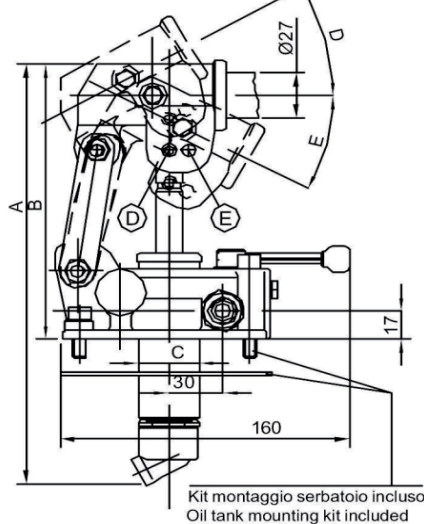
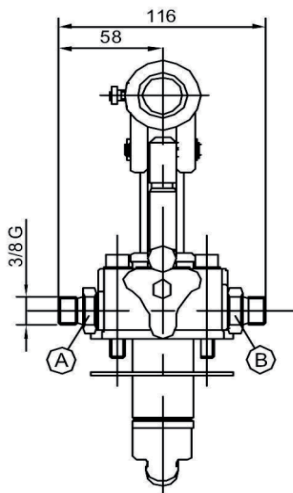

Kit montaggio serbatoio incluso
Oil tank mounting kit included

DIAGRAMMA DI CARICO
con spina in D (interasse 40 mm)
LOAD CURVE
pin in D (axle base 40 mm)

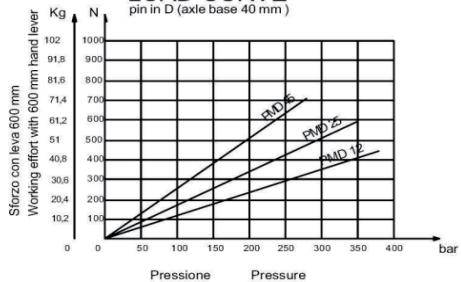

PMD 12/25/45 s

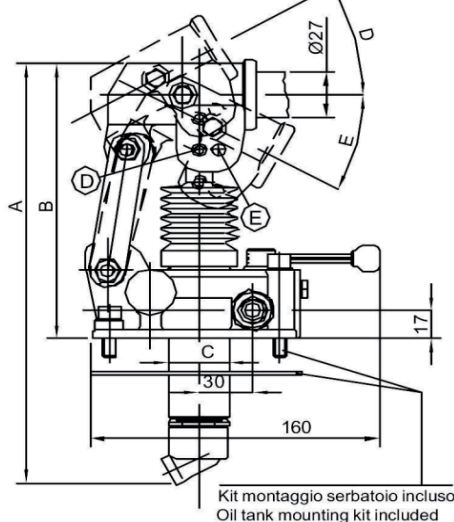
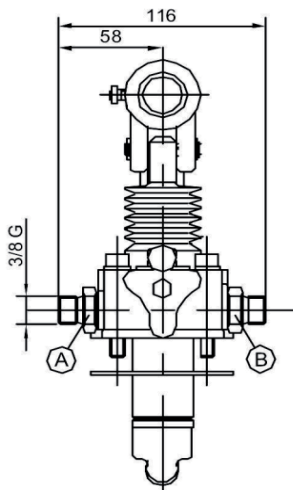

Kit montaggio serbatoio incluso
Oil tank mounting kit included

Interassi consigliati: PMD 12 40 mm (D)
Axle base advised: PMD 25 51 mm (E)
PMD 45 51 mm (E)

DIAGRAMMA DI CARICO
con spina in E (interasse 51 mm)
LOAD CURVE
pin in E (axle base 51 mm)

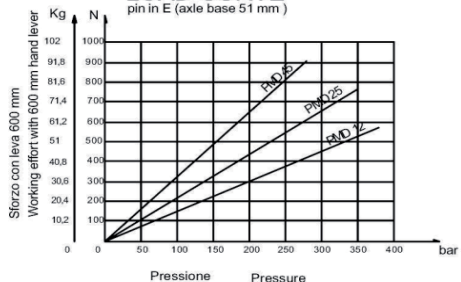

POMPA A MANO HAND PUMP

TIPO
TYPE

PMD
12-25-45

		POMPA A MANO PMD 12-25-45 con distributore 4/3 e valvola di massima pressione			HAND PUMP PMD 12-25-45 with 4/3 diverter and pressure relief valve	
		Pompa doppio effetto con distributore 4/3 per cilindro a doppio effetto per montaggio su serbatoio			Double-acting pump with 4/3 diverter for double-acting cylinder for assembly on tank	
Tipo di pompa Type of pump	Cilindr. (cm ³) Flow (cm ³)	Pressione (Pressure) (bar)		Massa (Kg) Weight (Kg)	Codice senza soffietti. Code without bellows	Codice con soffietti. Code with bellows
		eserciz. (exerciz.)	max.			
PMD 12	12,095	320	380	3,40	60550001	60550028
PMD 25	25,280	280	350	3,45	60560001	60560028
PMD 45	44,532	220	280	3,50	60570001	60570028

TABELLA DIMENSIONI SIZE TABLE

Tipo di pompa Type of pump	A (mm)	B (mm)	C (mm)	D (°)	E (°)
PMD 12	253	166	34	26	31
PMD 25	273	172	34	30	30
PMD 45	283	172	40	45	33

PMD 12/25/45 byB

Valvola di massima
pressione taratura
standard 100 bar
(Pressure relief valve
standard setting 100 bar)

Kit montaggio serbatoio incluso
Oil tank mounting kit included

DIAGRAMMA DI CARICO LOAD CURVE

con spina in D (interasse 40 mm)
pin in D (axle base 40 mm)

PMD 12/25/45 byB-s

Valvola di massima
pressione taratura
standard 100 bar
(Pressure relief valve
standard setting 100 bar)

Kit montaggio serbatoio incluso
Oil tank mounting kit included

DIAGRAMMA DI CARICO LOAD CURVE

con spina in E (interasse 51 mm)
pin in E (axle base 51 mm)

Interassi consigliati: PMD 12 40 mm (D)
Axle base advised: PMD 25 51 mm (E)
PMD 45 51 mm (E)

POMPA A MANO HAND PUMP

TIPO
TYPE

PMD
12-25-45

POMPA A MANO PMD 12-25-45
con distributore 4/3 e leva di scarico

HAND PUMP PMD 12-25-45
with 4/3 diverter and exhaust lever

Pompa doppio effetto con distributore 4/3 per cilindro a doppio
effetto per montaggio su serbatoio

Double-acting pump with 4/3 diverter for double-acting cylinder
for assembly on tank

Tipo di pompa Type of pump	Cilindr.(cm ³) Flow (cm ³)	Pressione (Pressure) (bar)		Massa (Kg) Weight (Kg)	Codice senza soffiet. Code without bellows	Codice con soffiet. Code with bellows
		eserciz.(exerciz.)	max.			
PMD 12	12,095	320	380	3,40	60550002	60550029
PMD 25	25,280	280	350	3,45	60560002	60560029
PMD 45	44,532	220	280	3,50	60570002	60570029

TABELLA DIMENSIONI
SIZE TABLE

Tipo di pompa Type of pump	A (mm)	B (mm)	C (mm)	D (°)	E (°)
PMD 12	253	166	34	26	31
PMD 25	273	172	34	30	30
PMD 45	283	172	40	45	33

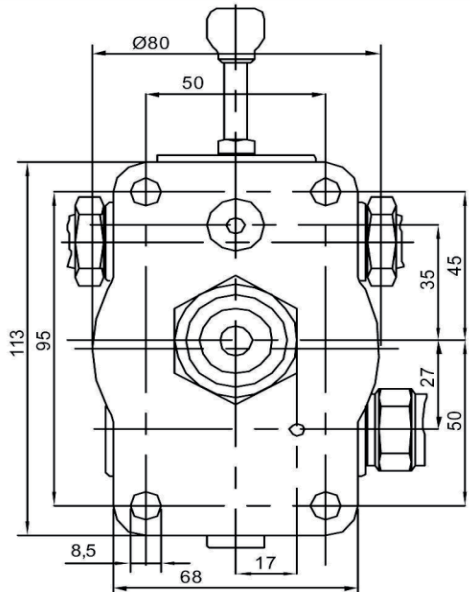
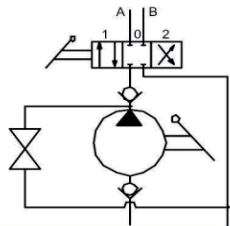

PMD 12/25/45 L

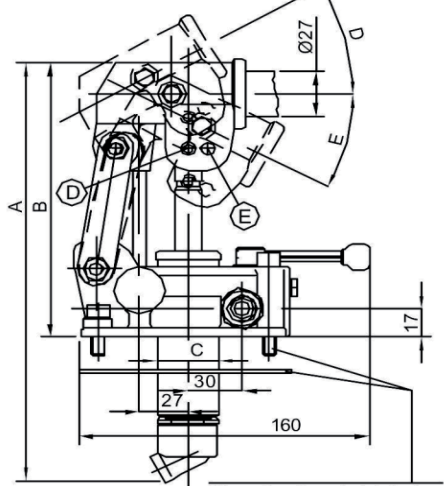
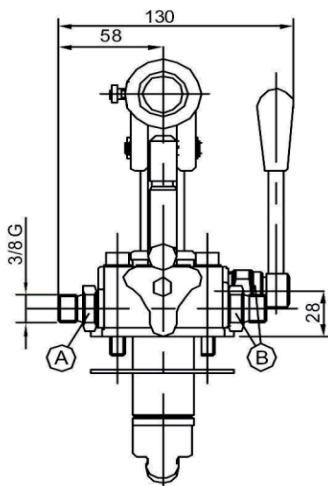

Kit montaggio serbatoio incluso
Oil tank mounting kit included

DIAGRAMMA DI CARICO
con spina in D (interasse 40 mm)
LOAD CURVE
pin in D (axle base 40 mm)

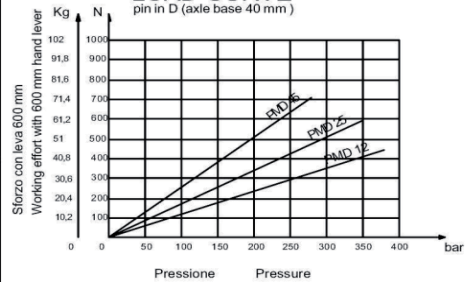

PMD 12/25/45 L-S

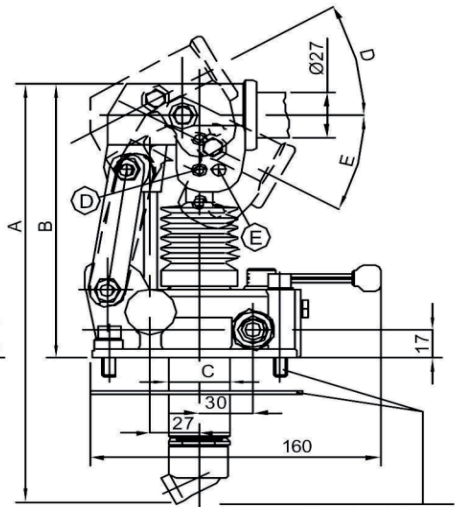
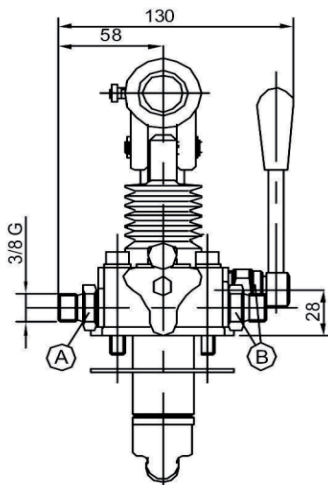

Kit montaggio serbatoio incluso
Oil tank mounting kit included

DIAGRAMMA DI CARICO
con spina in E (interasse 51 mm)
LOAD CURVE
pin in E (axle base 51 mm)

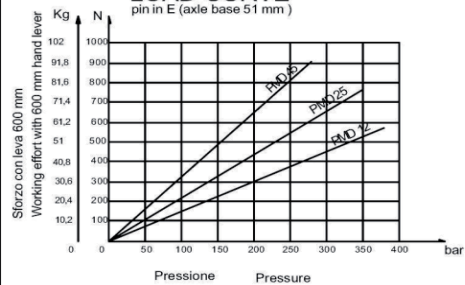

Interassi consigliati: PMD 12 40 mm (D)
Axle base advised: PMD 25 51 mm (E)
PMD 45 51 mm (E)

POMPA A MANO HAND PUMP

TIPO
TYPE

PMD
12-25-45

POMPA A MANO PMD 12-25-45
con distributore 4/3 , valvola di max pressione
e leva di scarico

HAND PUMP PMD 12-25-45
with 4/3 diverter, pressure relief valve
and exhaust lever

Pompa doppio effetto con distributore 4/3 per cilindro a doppio
effetto per montaggio su serbatoio

Double-acting pump with 4/3 diverter for double-acting cylinder
for assembly on tank

Tipo di pompa Type of pump	Cilindr.(cm ³) Flow (cm ³)	Pressione (Pressure) (bar)		Massa (Kg) Weight(Kg)	Codice senza soffiet. Code without bellows	Codice con soffiet. Code with bellows
		eserciz.(exerciz.)	max.			
PMD 12	12,095	320	380	3,40	60550003	60550030
PMD 25	25,280	280	350	3,45	60560003	60560030
PMD 45	44,532	220	280	3,50	60570003	60570030



TABELLA DIMENSIONI SIZE TABLE						
Tipo di pompa Type of pump	A (mm)	B (mm)	C (mm)	D (°)	E (°)	
PMD 12	253	166	34	26	31	
PMD 25	273	172	34	30	30	
PMD 45	283	172	40	45	33	



PMD 12/25/45 byA-L

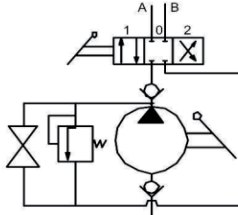
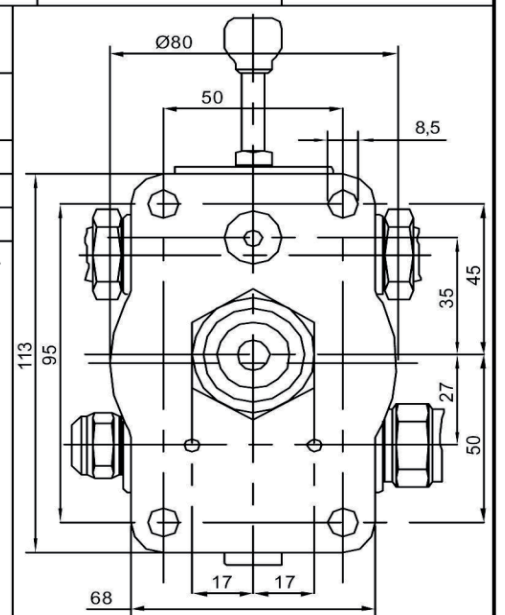
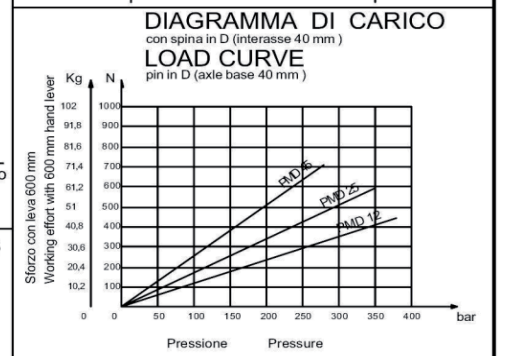
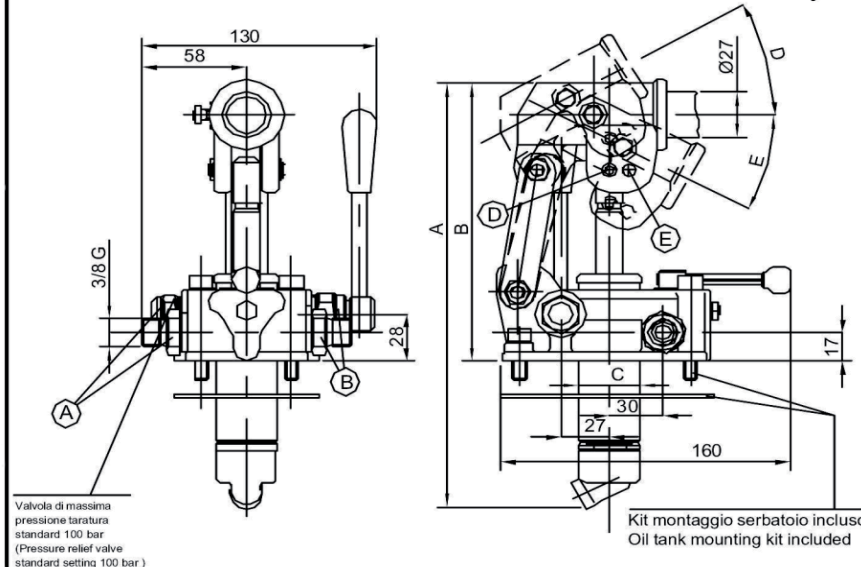

PMD 12/25/45 byA-L-s

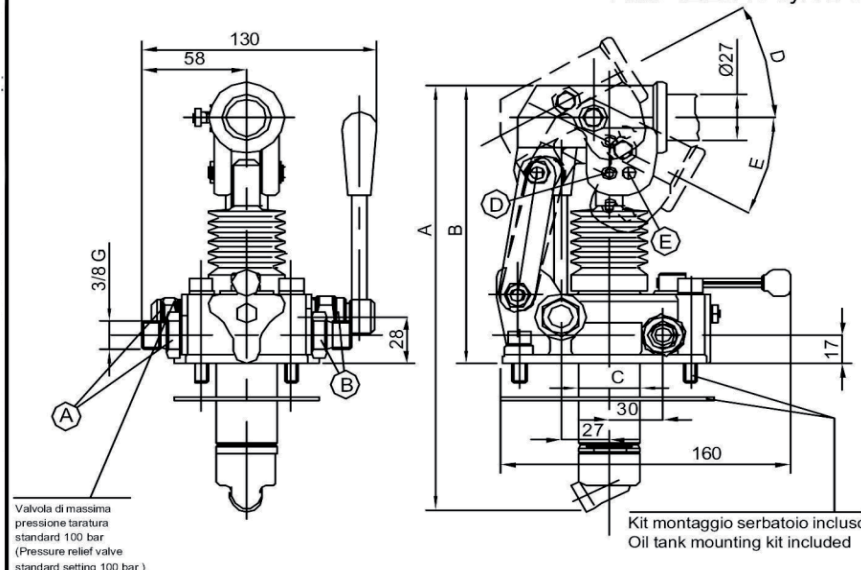

Interassi consigliati: PMD 12 40 mm (D)
Axle base advised: PMD 25 51 mm (E)
PMD 45 51 mm (E)

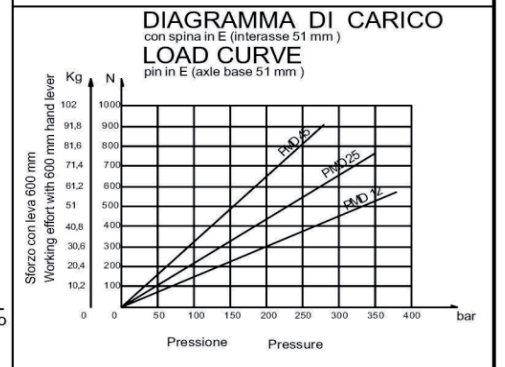

POMPA A MANO HAND PUMP

TIPO
TYPE

PMDVB 12-25-45

POMPA A MANO PMDVB 12-25-45 con distributore 4/3 e valvole di blocco	HAND PUMP PMDVB 12-25-45 with 4/3 diverter and dual pilot check valve
Pompa doppio effetto con distributore 4/3 per cilindro a doppio effetto per montaggio su serbatoio	Double-acting pump with 4/3 diverter for double-acting cylinder for assembly on tank

Tipo di pompa Type of pump	Cilindr. (cm ³) Flow (cm ³)	Pressione (Pressure) (bar)		Massa (Kg) Weight (Kg)	Codice senza soffiet. Code without bellows	Codice con soffiet. Code with bellows
		eserciz. (exerciz.)	max.			
PMDVB 12	12,095	320	380	3,40	60600015	60600016
PMDVB 25	25,280	280	350	3,45	60610015	60610016
PMDVB 45	44,532	220	280	3,50	60620015	60620016

Repp. pilotaggio 5:1
Pilot ratio 5:1

**TABELLA DIMENSIONI
SIZE TABLE**

Tipo di pompa Type of pump	A (mm)	B (mm)	C (mm)	D (°)	E (°)
PMDVB 12	253	166	34	26	31
PMDVB 25	273	172	34	30	30
PMDVB 45	283	172	40	45	33

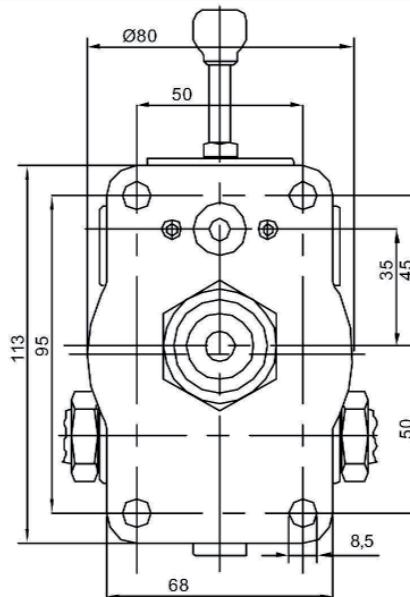

PMDVB 12/25/45



DIAGRAMMA DI CARICO
con spina in D (interasse 40 mm)
LOAD CURVE
pin in D (axle base 40 mm)



PMDVB 12/25/45 s

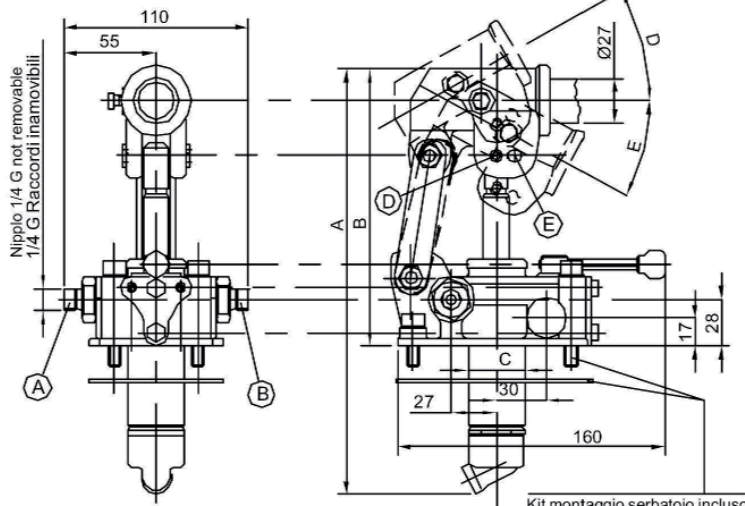
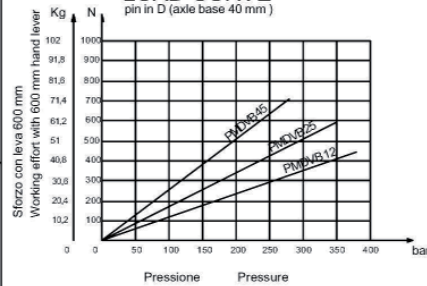
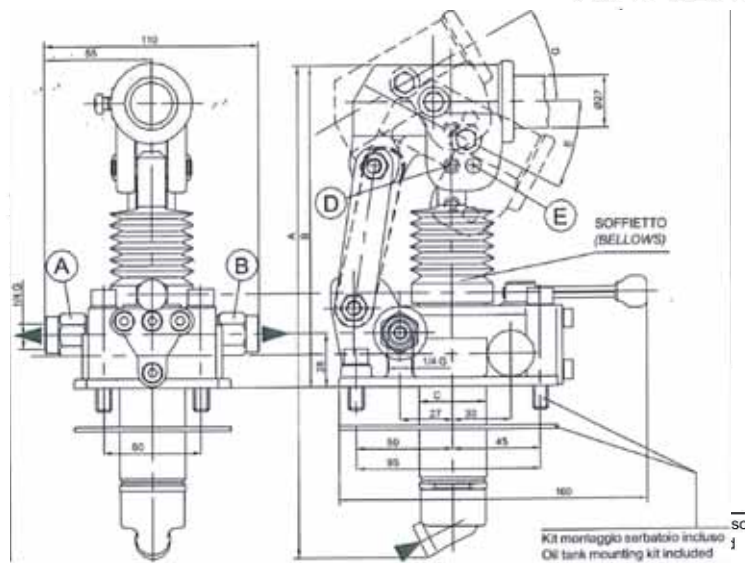

Interassi consigliati: PMDVB 12 40 mm (D)
Axle base advised: PMDVB 25 51 mm (E)
PMDVB 45 51 mm (E)

DIAGRAMMA DI CARICO
con spina in E (interasse 51 mm)
LOAD CURVE
pin in E (axle base 51 mm)

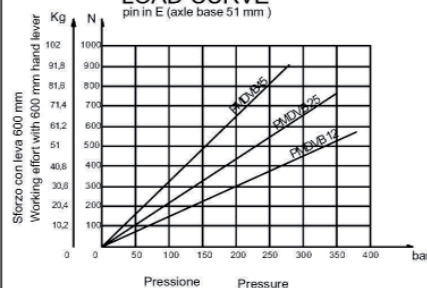

POMPA A MANO HAND PUMP

TIPO
TYPE

PMDVB
12-25-45

POMPA A MANO PMDVB 12-25-45
con distributore 4/3 e valvole di blocco
e valvola di max pressione

HAND PUMP PMDVB 12-25-45
with 4/3 diverter, dual pilot check valve
and pressure relief valve

Pompa doppio effetto con distributore 4/3 per cilindro a doppio
effetto per montaggio su serbatoio

Double-acting pump with 4/3 diverter for double-acting cylinder
for assembly on tank

Tipo di pompa Type of pump	Cilindr. (cm ³) Flow (cm ³)	Pressione (Pressure) (bar)		Massa (Kg) Weight (Kg)	Codice senza soffiet. Code without bellows	Codice con soffiet. Code with bellows
		eserciz. (exerciz.)	max.			
PMDVB 12	12,095	320	380	3,40	60600017	60600018
PMDVB 25	25,280	280	350	3,45	60610017	60610018
PMDVB 45	44,532	220	280	3,50	60620017	60620018

Tipo di pompa Type of pump	TABELLA DIMENSIONI SIZE TABLE				
	A (mm)	B (mm)	C (mm)	D (°)	E (°)
PMDVB 12	253	166	34	26	31
PMDVB 25	273	172	34	30	30
PMDVB 45	283	172	40	45	33

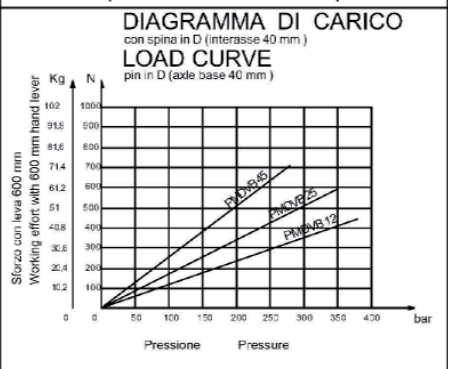
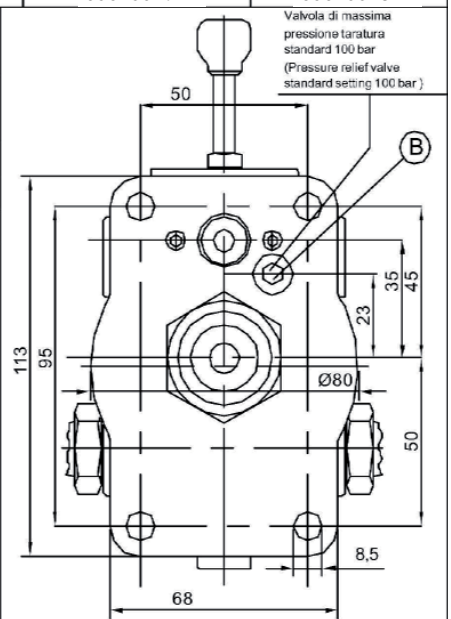
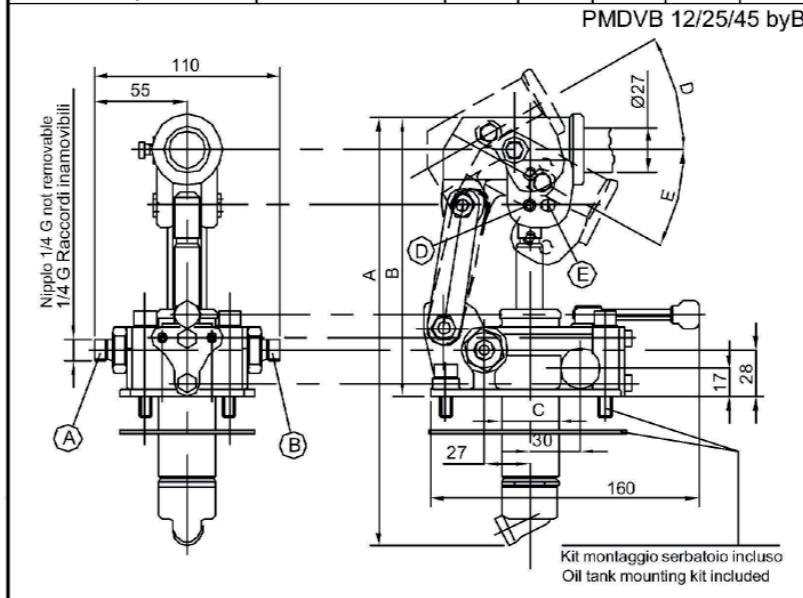

Interassi consigliati: PMDVB 12 40 mm (D)
Axle base advised: PMDVB 25 51 mm (E)
PMDVB 45 51 mm (E)

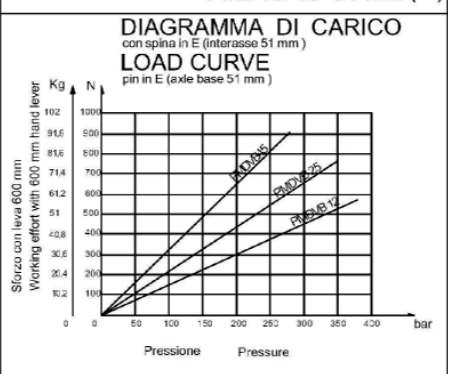
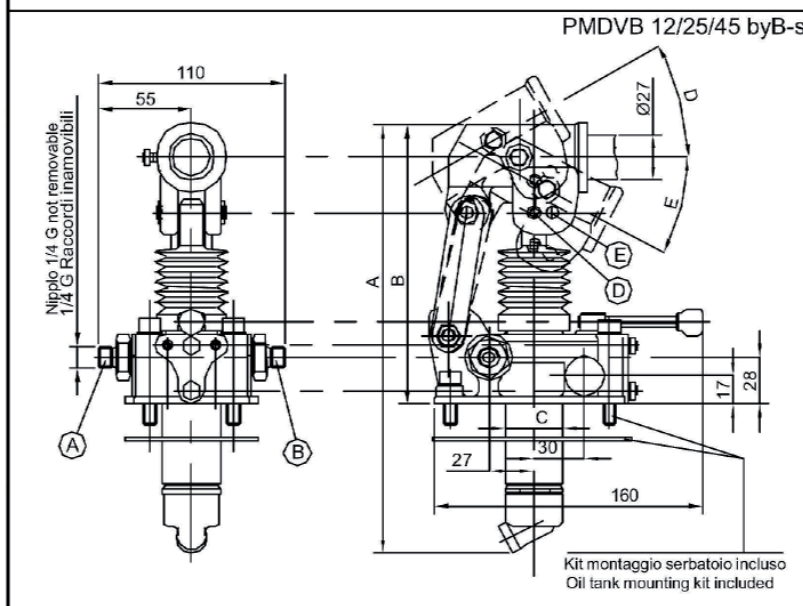

POMPA A MANO HAND PUMP

**TIPO
TYPE**

**PMDVB
12-25-45**

POMPA A MANO PMDVB 12-25-45
con distributore 4/3 e valvole di blocco
e valvole di max pressione

HAND PUMP PMDVB 12-25-45
with 4/3 diverter, dual pilot check valve
and pressure relief valve

Pompa doppio effetto con distributore 4/3 per cilindro a doppio
effetto per montaggio su serbatoio

Double-acting pump with 4/3 diverter for double-acting cylinder
for assembly on tank

Tipo di pompa Type of pump	Cilindr.(cm ³) Flow (cm ³)	Pressione (Pressure)(bar)		Massa (Kg) Weight(Kg)	Codice senza soffiet. Code without bellows	Codice con soffiet. Code with bellows
		eserciz.(exerciz.)	max.			
PMDVB 12	12,095	320	380	3,40	60600019	60600020
PMDVB 25	25,280	280	350	3,45	60610019	60610020
PMDVB 45	44,532	220	280	3,50	60620019	60620020

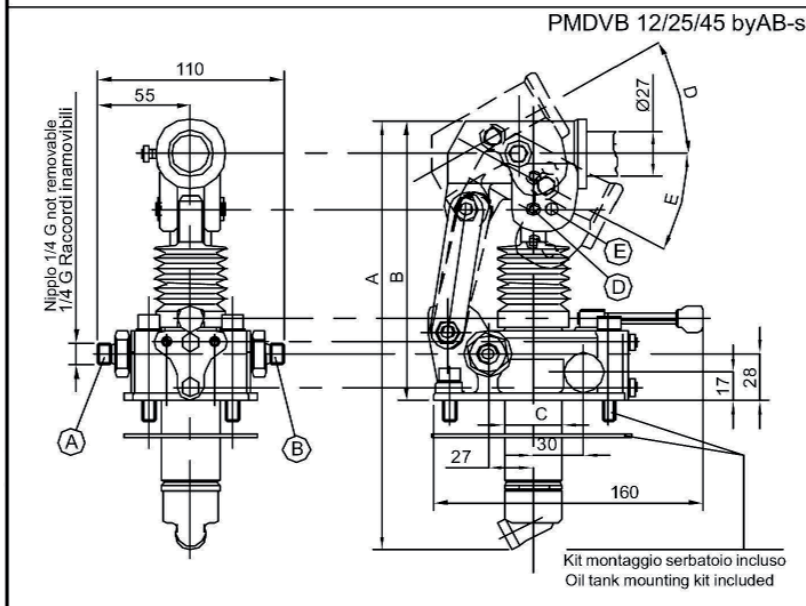
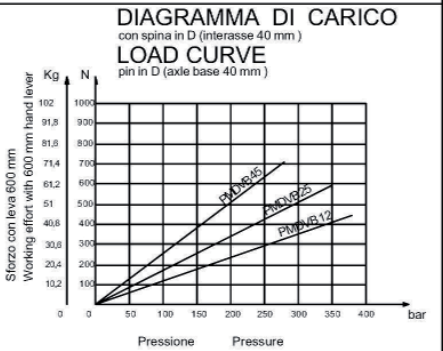
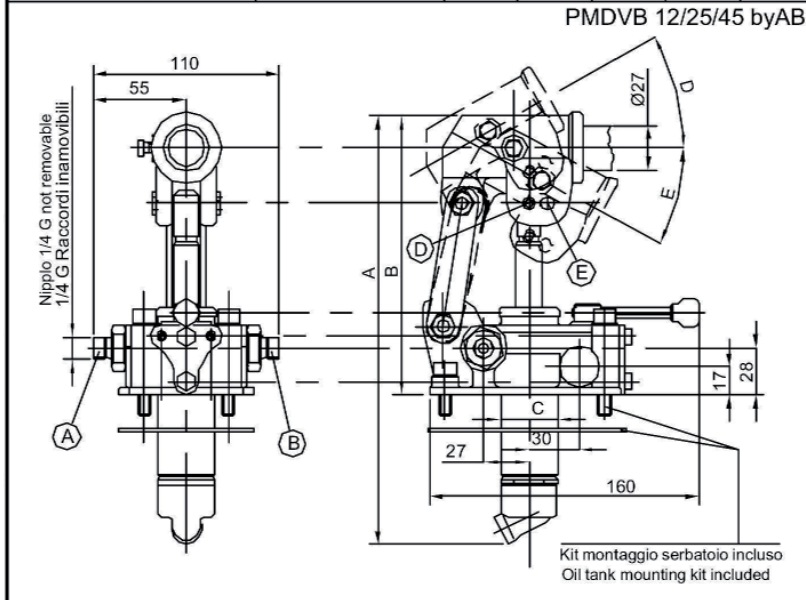
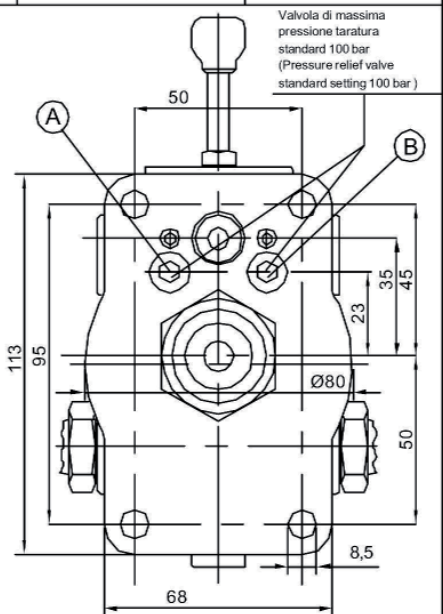
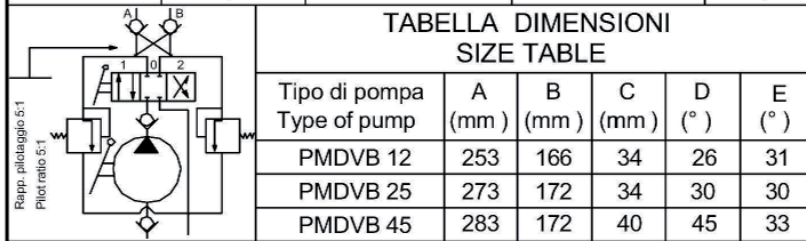

Interassi consigliati: PMDVB 12 40 mm (D)
Axle base advised: PMDVB 25 51 mm (E)
PMDVB 45 51 mm (E)

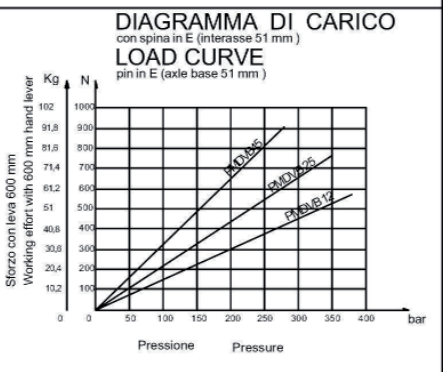

POMPA A MANO HAND PUMP

TIPO
TYPE

PM 8-15

POMPA A MANO PMSE 8-15 con volantino di scarico	HAND PUMP PM 8-15 with exhaust handwheel
Pompa a semplice effetto per cilindro a semplice effetto per montaggio su serbatoio	Single-acting pump for a single-acting cylinder for assembly on tank

Tipo di pompa Type of pump	Cilindr. (cm ³) Flow (cm ³)	Pressione (Pressure) (bar)		Massa (Kg) Weight (Kg)	Codice senza soffiet. Code without bellows	Codice con soffietti. Code with bellows
		eserciz. (exerciz.)	max.			
PMSE 8	8,042	325	380	3,2	60650000	60650027
PMSE 15	15,205	285	350	3,2	60660000	60660027



DIAGRAMMA DI CARICO
LOAD CURVE



PMSE 8/15

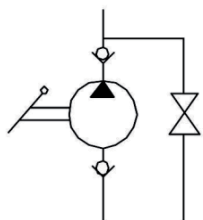
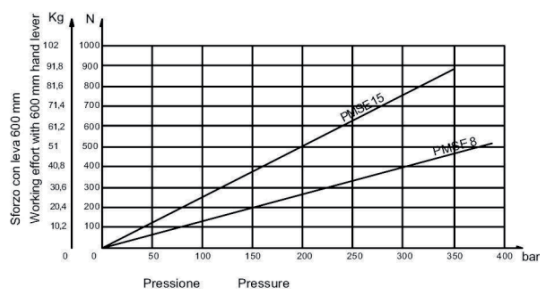
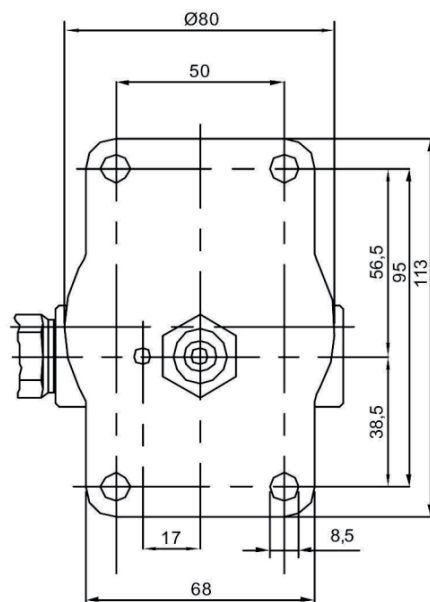
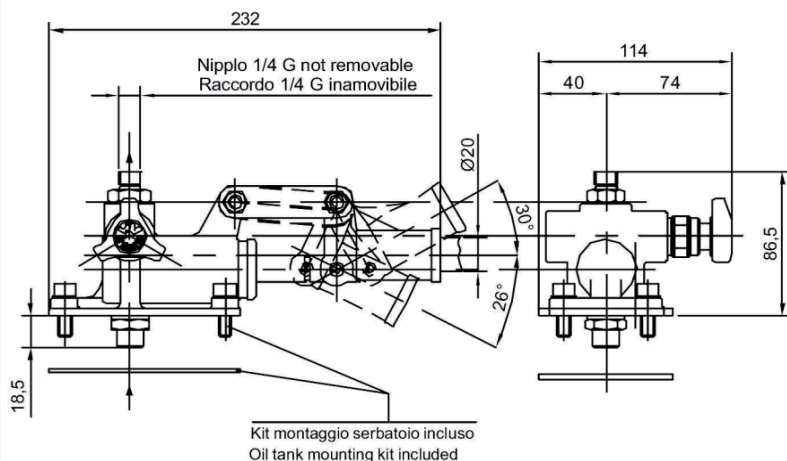

PMSE 8/15 s

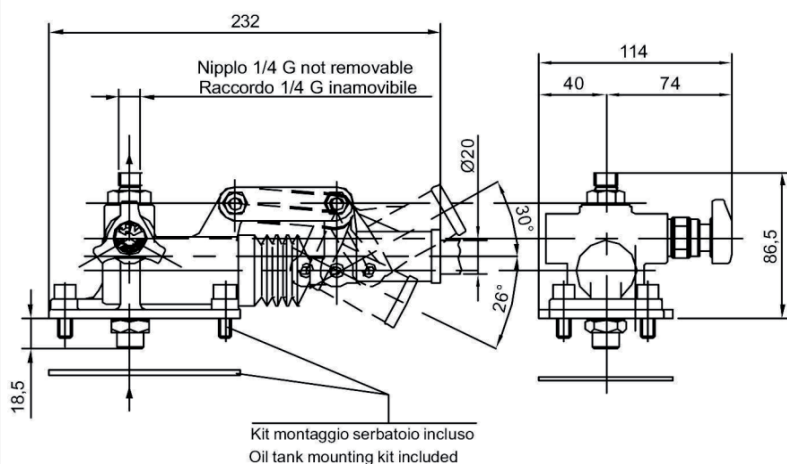

POMPA A MANO HAND PUMP

TIPO
TYPE

PM 8-15

POMPA A MANO PMSE 8-15 con volantino di scarico e valvola di by-pass	HAND PUMP PM 8-15 with exhaust handwheel and pressure relief valve
Pompa a semplice effetto per cilindro a semplice effetto per montaggio su serbatoio	Single-acting pump for a single-acting cylinder for assembly on tank

Tipo di pompa Type of pump	Cilindr. (cm ³) Flow (cm ³)	Pressione (Pressure) (bar)		Massa (Kg) Weight (Kg)	Codice senza soffieta Code without bellows	Codice con soffieta Code with bellows
		eserciz. (exerciz.)	max.			
PMSE 8	8,042	325	380	3,2	60650001	60650028
PMSE 15	15,205	285	350	3,2	60660001	60660028



DIAGRAMMA DI CARICO
LOAD CURVE



PMSE 8/15 byB

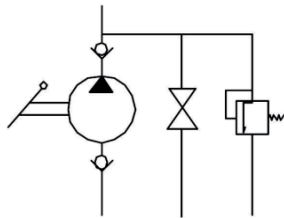
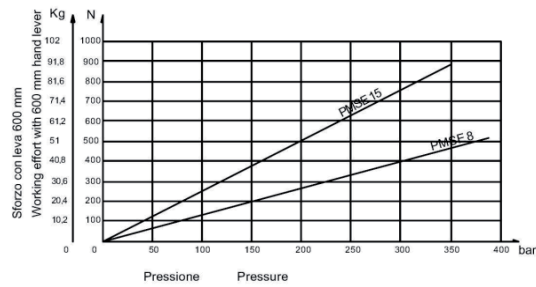
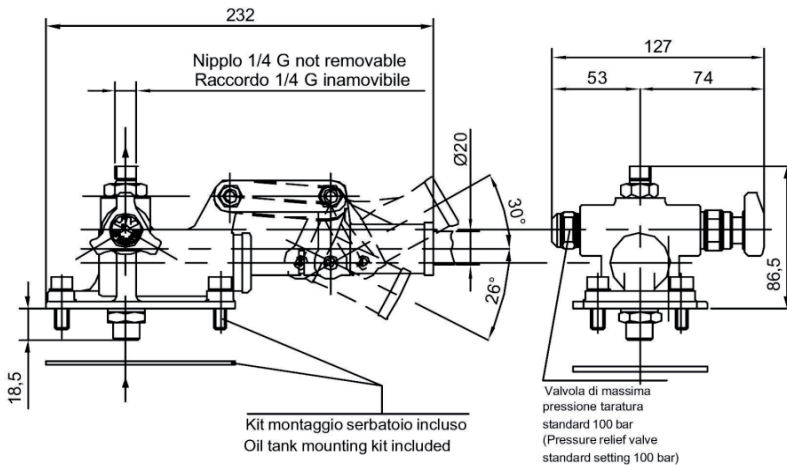

PMSE 8/15 byB-s

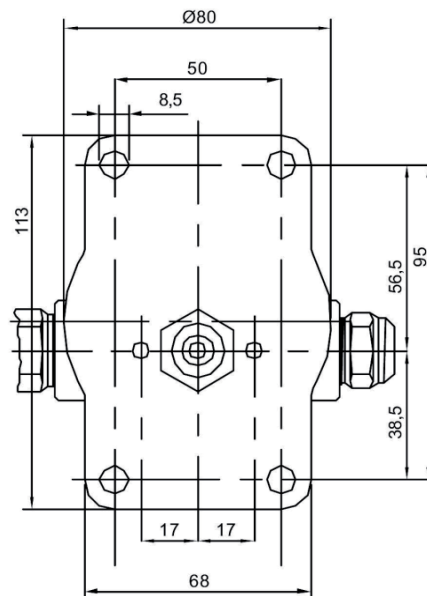
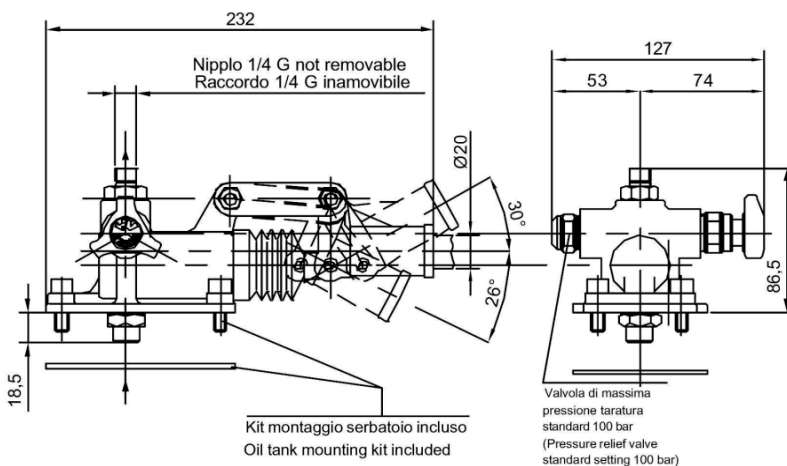

POMPA A MANO HAND PUMP

TIPO
TYPE

PM 8-15

POMPA A MANO PMSE 8-15 senza volantino di scarico	HAND PUMP PM 8-15 without exhaust handwheel
Pompa a semplice effetto per cilindro a semplice effetto per montaggio su serbatoio	Single-acting pump for a single-acting cylinder for assembly on tank

Tipo di pompa Type of pump	Cilindr.(cm ³) Flow (cm ³)	Pressione(Pressure)(bar)		Massa (Kg) Weight (Kg)	Codice senza soffiet. Code without bellows	Codice con soffiet. Code with bellows
		eserciz.(exerciz.)	max.			
PMSE 8	8,042	325	380	3,2	60650002	60650029
PMSE 15	15,205	285	350	3,2	60660002	60660029



DIAGRAMMA DI CARICO
LOAD CURVE



PMSE 8/15 e

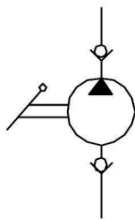
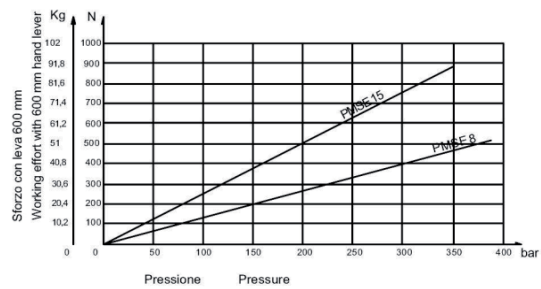
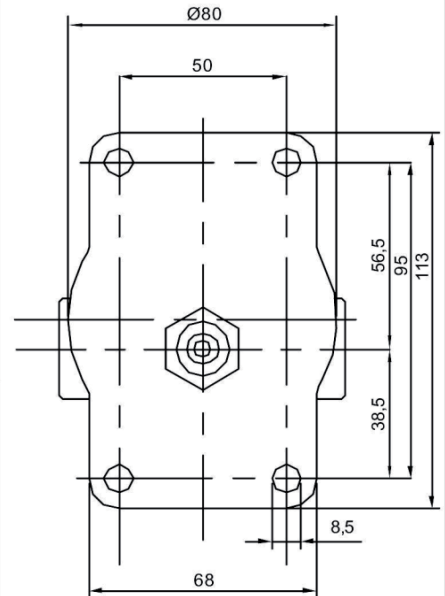
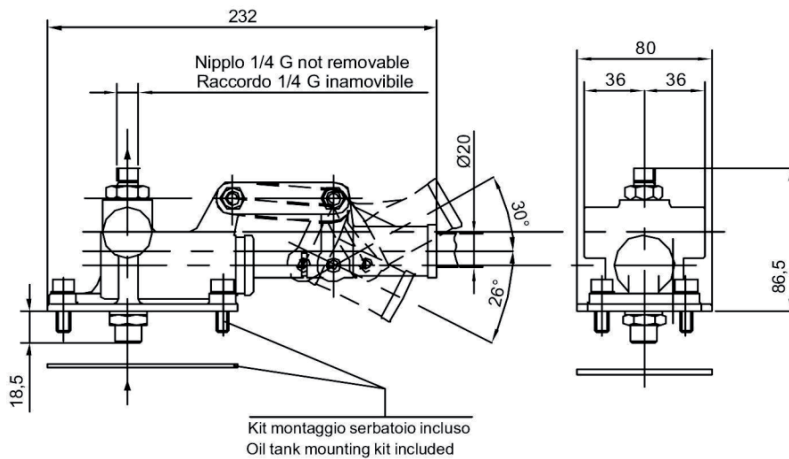

PMSE 8/15 e-s

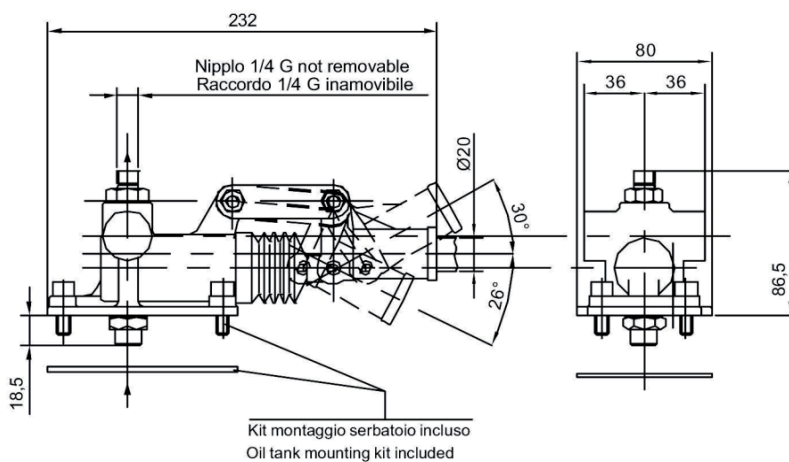

Kit montaggio serbatoio incluso
Oil tank mounting kit included

Kit montaggio serbatoio incluso
Oil tank mounting kit included

POMPA A MANO HAND PUMP

TIPO
TYPE

PM 8-15

POMPA A MANO PMSE 8-15 senza volantino di scarico, con valvola di by-pass	HAND PUMP PM 8-15 without exhaust handwheel, with pressure relief valve
Pompa a semplice effetto per cilindro a semplice effetto per montaggio su serbatoio	Single-acting pump for a single-acting cylinder for assembly on tank

Tipo di pompa Type of pump	Cilindr.(cm ³) Flow (cm ³)	Pressione(Pressure)(bar)		Massa (Kg) Weight(Kg)	Codice senza soffieta. Code without bellows	Codice con soffieta. Code with bellows
		eserciz.(exerciz.)	max.			
PMSE 8	8,042	325	380	3,2	60650003	60650030
PMSE 15	15,205	285	350	3,2	60660003	60660030



DIAGRAMMA DI CARICO
LOAD CURVE



PMSE 8/15 byA-e

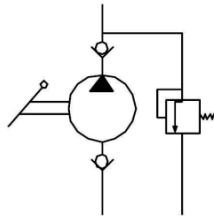
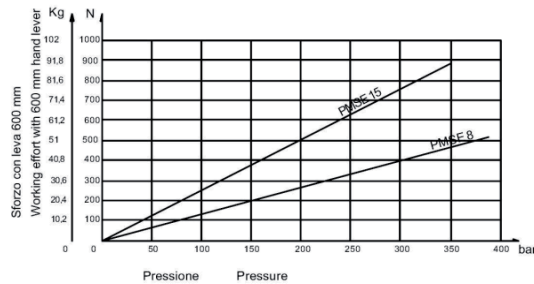
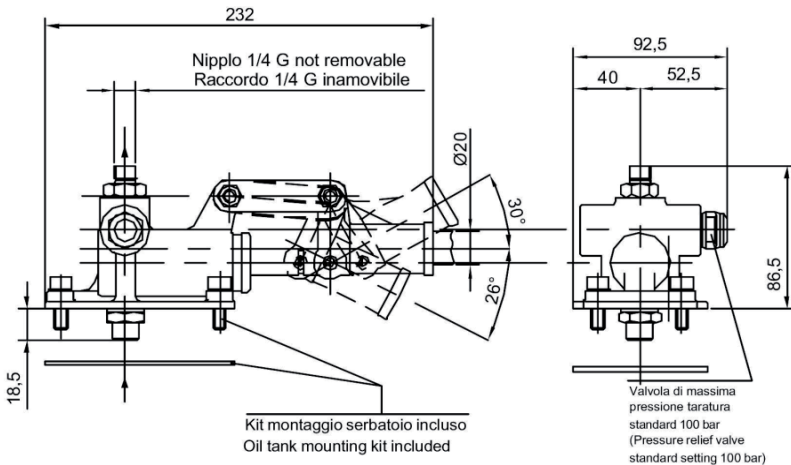

PMSE 8/15 byA-e-s

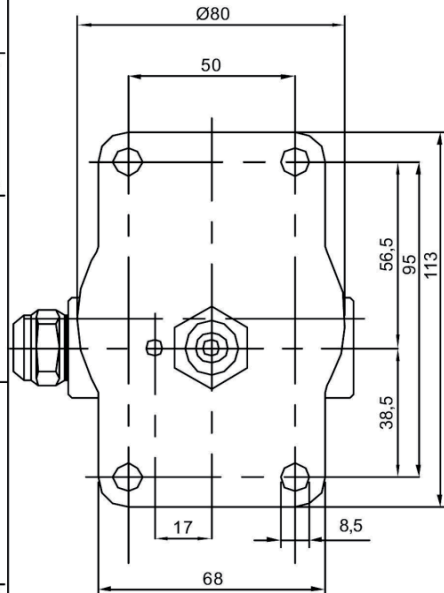
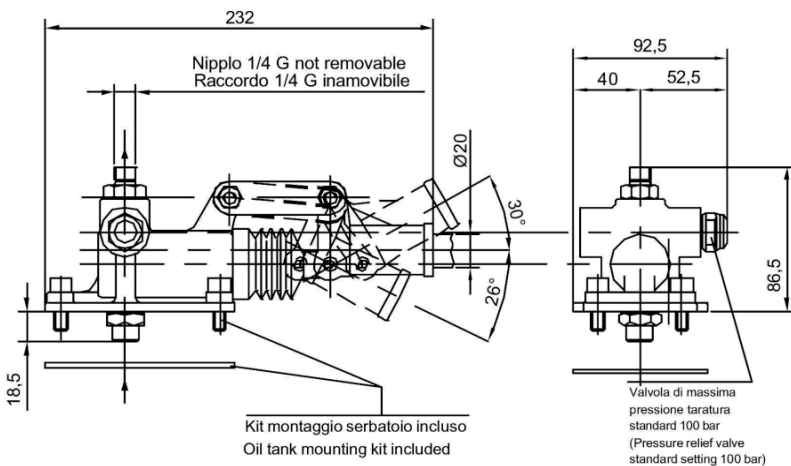

POMPA A MANO HAND PUMP

TIPO
TYPE

PM 20-30-40

POMPA A MANO PMSE 20-30-40 con volantino di scarico	HAND PUMP PM 20-30-40 with exhaust handwheel
Pompa a semplice effetto per cilindro a semplice effetto per montaggio su serbatoio	Single-acting pump for a single-acting cylinder for assembly on tank

Tipo di pompa Type of pump	Cilindr.(cm ³) Flow (cm ³)	Pressione (Pressure)(bar) eserciz.(exerciz.)		Massa (Kg) Weight(Kg)	Codice senza soffiet. Code without bellows	Codice con soffiet. Code with bellows
			max.			
PMSE 20	20,527	185	240	3,1	60670000	60670027
PMSE 30	30,262	160	185	3,2	60680000	60680027
PMSE 40	40,290	130	160	3,3	60690000	60690027

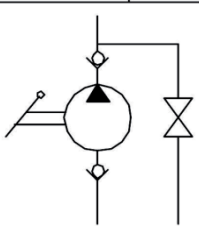

**TABELLA DIMENSIONI
SIZE TABLE**

Tipo di pompa Type of pump	A (mm)	B (mm)	C (mm)	D (°)	E (°)
PMSE 20	249	167	34	35	29
PMSE 30	252	167	34	38	26
PMSE 40	252	167	40	38	26

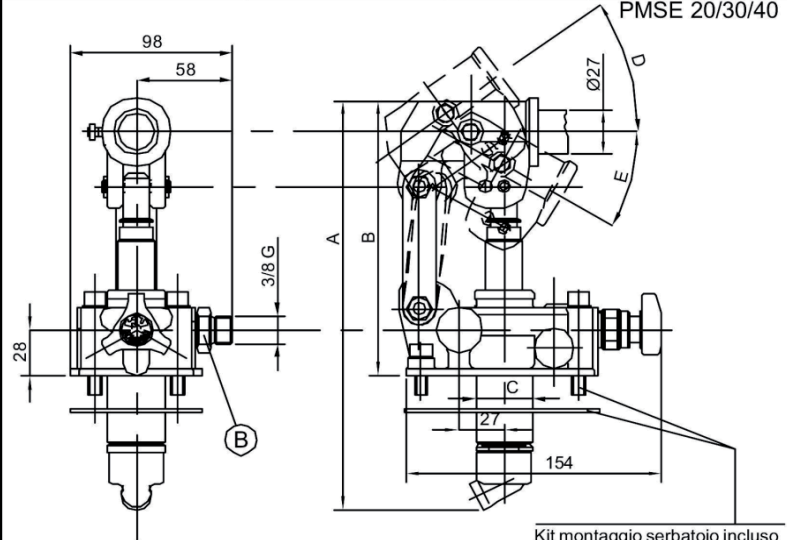
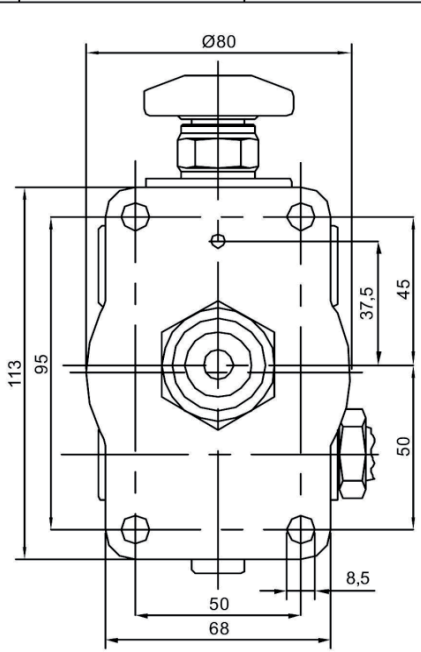

Kit montaggio serbatoio incluso
Oil tank mounting kit included

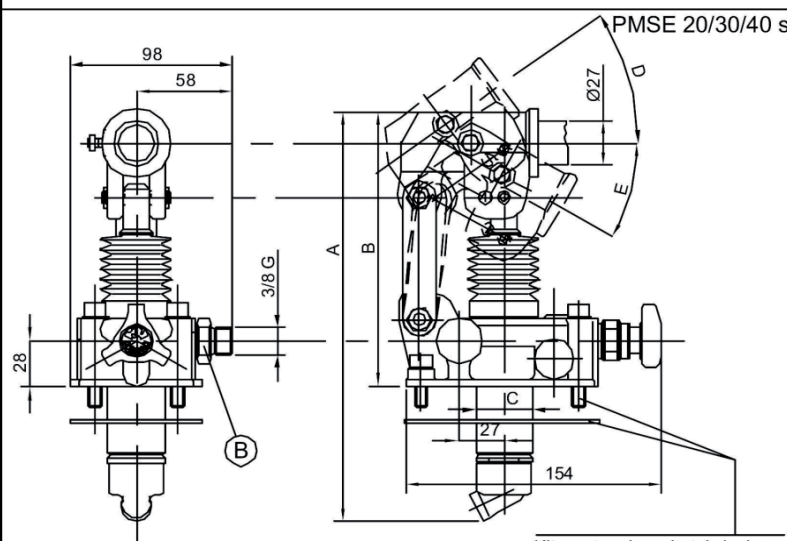

Kit montaggio serbatoio incluso
Oil tank mounting kit included

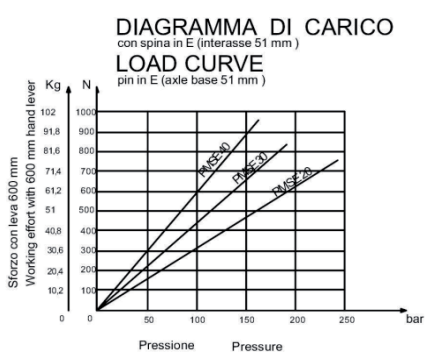

POMPA A MANO HAND PUMP

TIPO
TYPE

PM 20-30-40

POMPA A MANO PMSE 20-30-40
con volantino di scarico e valvola di by pass

HAND PUMP PM 20-30-40
with exhaust handwheel and pressure relief valve

Pompa a semplice effetto per cilindro a semplice effetto
per montaggio su serbatoio

Single-acting pump for a single-acting cylinder
for assembly on tank

Tipo di pompa Type of pump	Cilindr. (cm ³) Flow (cm ³)	Pressione (Pressure) (bar)		Massa (Kg) Weight (Kg)	Codice senza soffieta. Code without bellows	Codice con soffieta. Code with bellows
		eserciz. (exerciz.)	max.			
PMSE 20	20,527	185	240	3,1	60670001	60670028
PMSE 30	30,262	160	185	3,2	60680001	60680028
PMSE 40	40,290	130	160	3,3	60690001	60690028

TABELLA DIMENSIONI
SIZE TABLE

Tipo di pompa Type of pump	A (mm)	B (mm)	C (mm)	D (°)	E (°)
PMSE 20	249	167	34	35	29
PMSE 30	252	167	34	38	26
PMSE 40	252	167	40	38	26

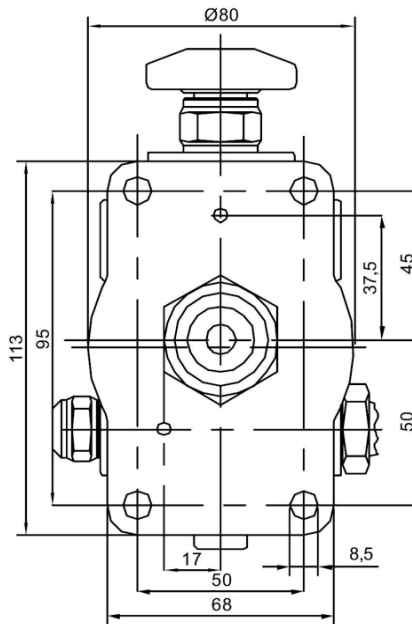
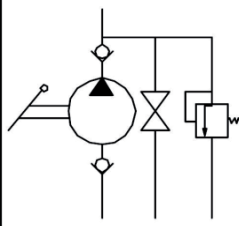

PMSE 20/30/40 byA

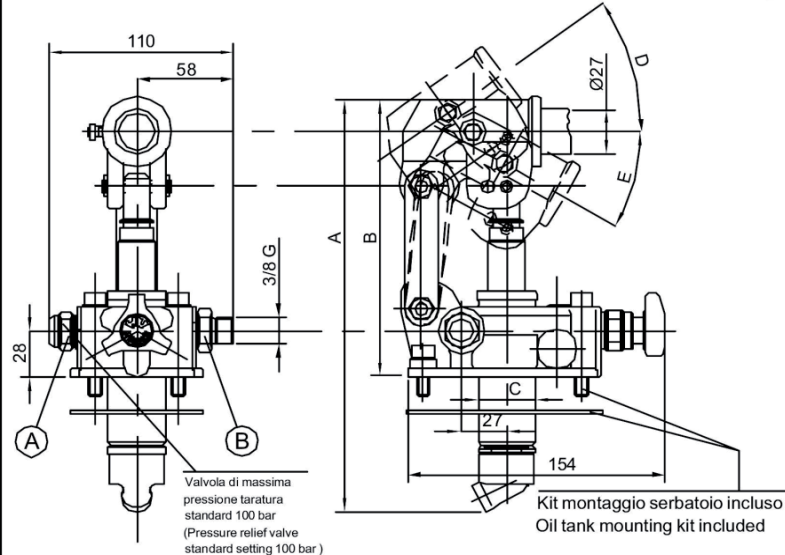

PMSE 20/30/40 byA-s



DIAGRAMMA DI CARICO
con spina in E (interasse 51 mm)
LOAD CURVE
pin in E (axle base 51 mm)



POMPA A MANO HAND PUMP

TIPO
TYPE

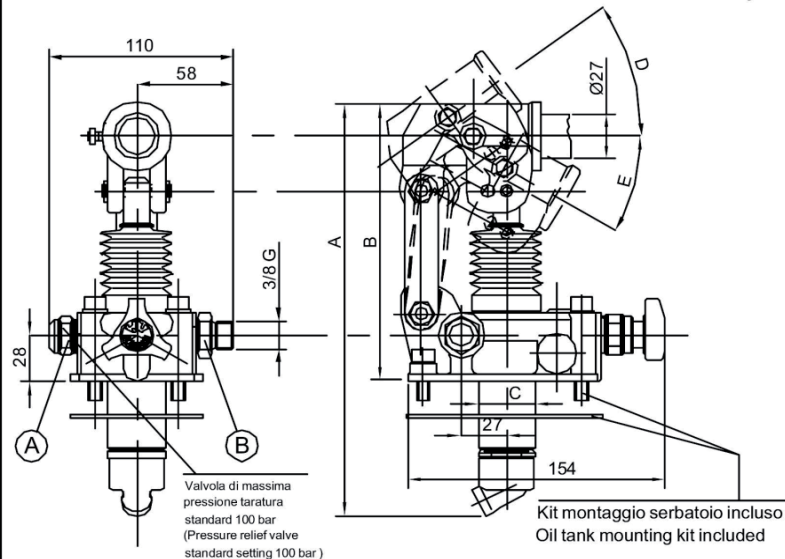
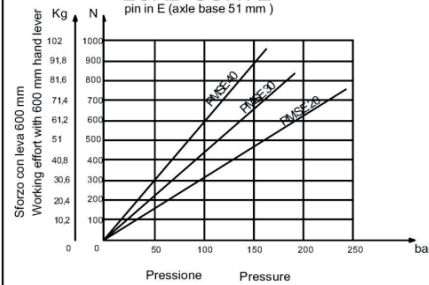
PM 20-30-40

POMPA A MANO PMSE 20-30-40
senza volantino di scarico

HAND PUMP PM 20-30-40
without exhaust handwheel

Pompa a semplice effetto per cilindro a semplice effetto
per montaggio su serbatoio

Single-acting pump for a single-acting cylinder
for assembly on tank

Tipo di pompa Type of pump	Cilindr.(cm ³) Flow (cm ³)	Pressione (Pressure)(bar)		Massa (Kg) Weight(Kg)	Codice senza soffiet. Code without bellows	Codice con soffiet. Code with bellows
		eserciz.(exerciz.)	max.			
PMSE 20	20,527	185	240	3,1	60670002	60670029
PMSE 30	30,262	160	185	3,2	60680002	60680029
PMSE 40	40,290	130	160	3,3	60690002	60690029

TABELLA DIMENSIONI
SIZE TABLE

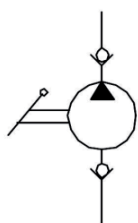

Tipo di pompa Type of pump	A (mm)	B (mm)	C (mm)	D (°)	E (°)
PMSE 20	249	167	34	35	29
PMSE 30	252	167	34	38	26
PMSE 40	252	167	40	38	26

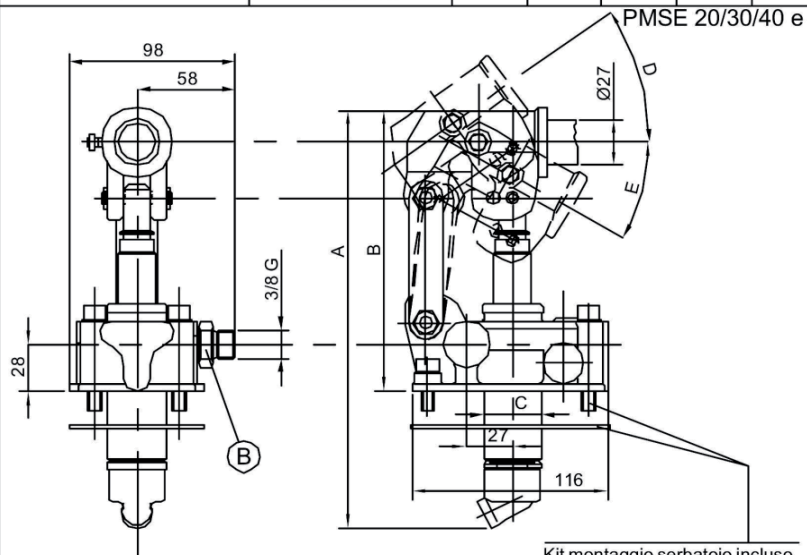
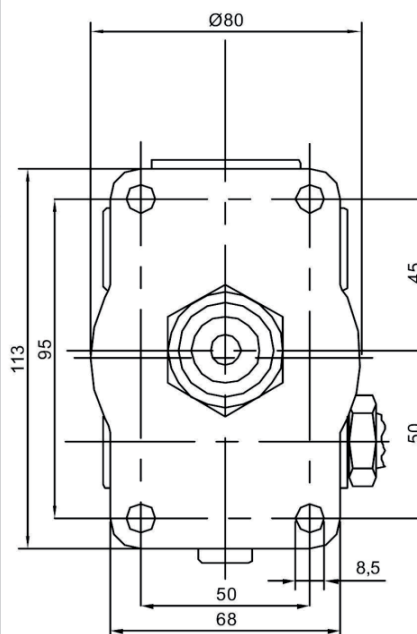

Kit montaggio serbatoio incluso
Oil tank mounting kit included

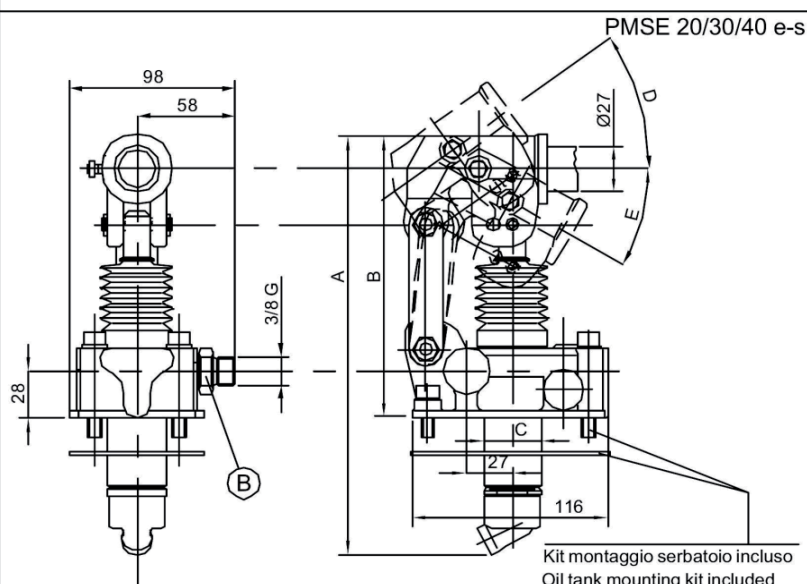

Kit montaggio serbatoio incluso
Oil tank mounting kit included

DIAGRAMMA DI CARICO
con spina in E (interasse 51 mm)
LOAD CURVE
pin in E (axle base 51 mm)

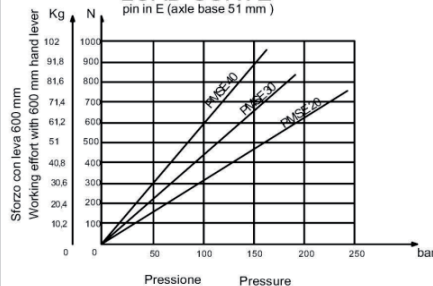

POMPA A MANO HAND PUMP

TIPO
TYPE

PM 20-30-40

POMPA A MANO PMSE 20-30-40
senza volantino, con valvola di by pass

HAND PUMP PM 20-30-40
without exhaust handwheel, with pressure
relief valve

Pompa a semplice effetto per cilindro a semplice effetto
per montaggio su serbatoio

Single-acting pump for a single-acting cylinder
for assembly on tank

Tipo di pompa Type of pump	Cilindr. (cm ³) Flow (cm ³)	Pressione (Pressure) (bar)		Massa (Kg) Weight (Kg)	Codice senza soffiet. Code without bellows	Codice con soffiet. Code with bellows
		eserciz. (exerciz.)	max.			
PMSE 20	20,527	185	240	3,1	60670003	60670030
PMSE 30	30,262	160	185	3,2	60680003	60680030
PMSE 40	40,290	130	160	3,3	60690003	60690030

TABELLA DIMENSIONI
SIZE TABLE

Tipo di pompa Type of pump	A (mm)	B (mm)	C (mm)	D (°)	E (°)
PMSE 20	249	167	34	35	29
PMSE 30	252	167	34	38	26
PMSE 40	252	167	40	38	26

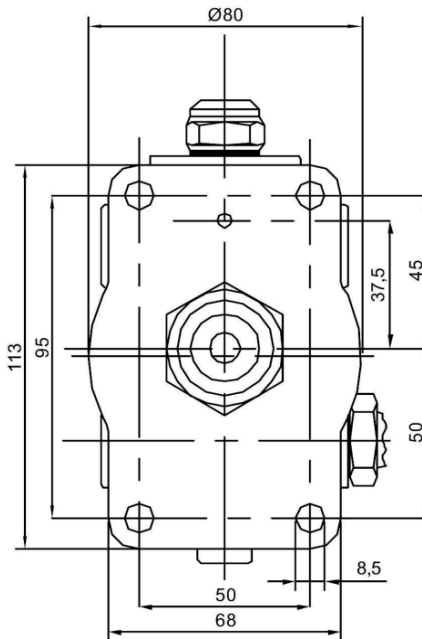
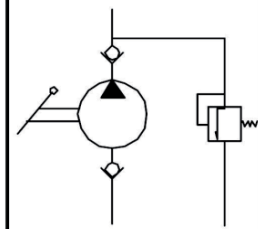

PMSE 20/30/40 byC

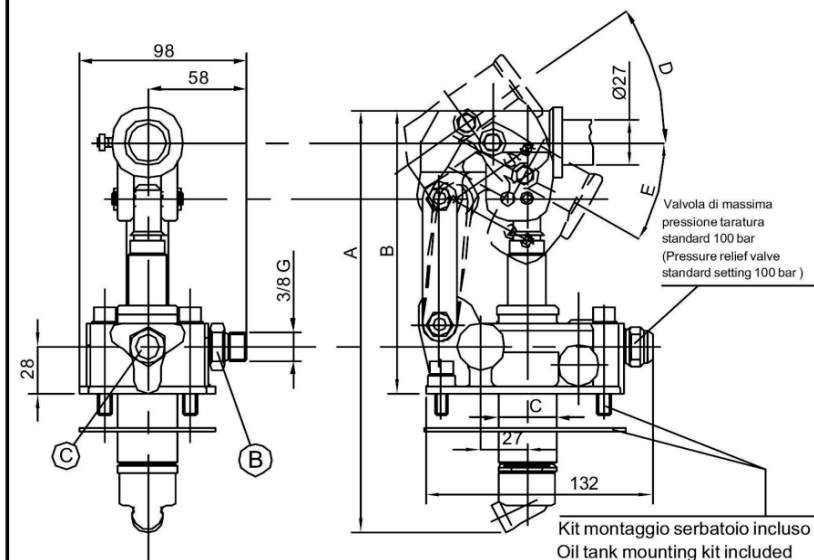

PMSE 20/30/40 byC-s



DIAGRAMMA DI CARICO
con spina in E (interasse 51 mm)
LOAD CURVE
pin in E (axle base 51 mm)



POMPA A MANO HAND PUMP

TIPO
TYPE

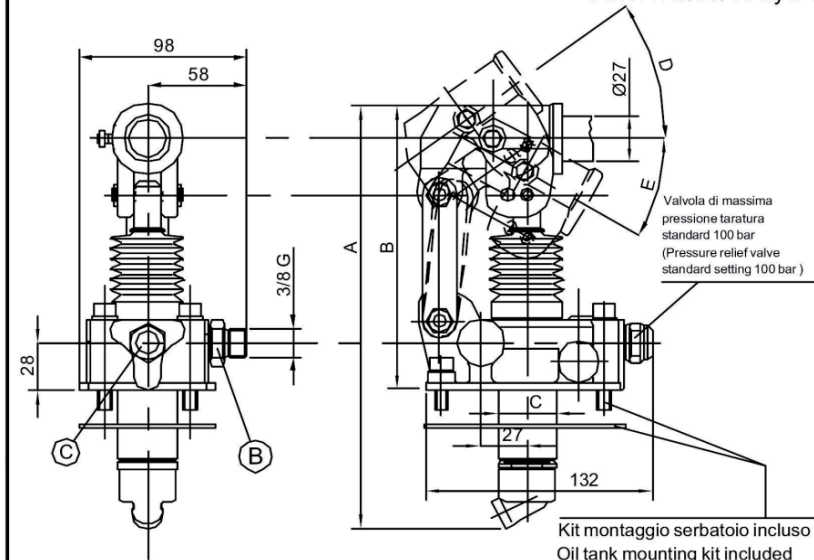
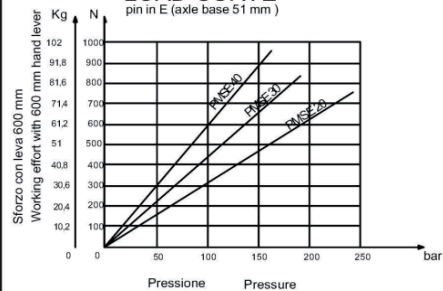
PM 20-30-40

POMPA A MANO PMSE 20-30-40
con leva di scarico

HAND PUMP PM 20-30-40
with exhaust lever

Pompa a semplice effetto per cilindro a semplice effetto
per montaggio su serbatoio

Single-acting pump for a single-acting cylinder
for assembly on tank

Tipo di pompa Type of pump	Cilindr. (cm ³) Flow (cm ³)	Pressione (Pressure) (bar)		Massa (Kg) Weight (Kg)	Codice senza soffiet. Code without bellows	Codice con soffiet. Code with bellows
		eserciz. (exerciz.)	max.			
PMSE 20	20,527	185	240	3,1	60670004	60670031
PMSE 30	30,262	160	185	3,2	60680004	60680031
PMSE 40	40,290	130	160	3,3	60690004	60690031

TABELLA DIMENSIONI
SIZE TABLE

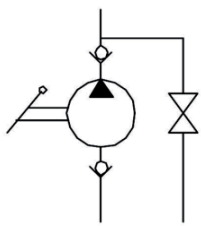

Tipo di pompa Type of pump	A (mm)	B (mm)	C (mm)	D (°)	E (°)
PMSE 20	249	167	34	35	29
PMSE 30	252	167	34	38	26
PMSE 40	252	167	40	38	26

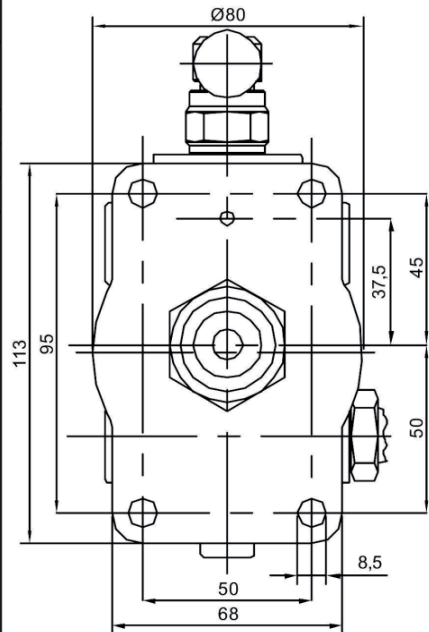

PMSE 20/30/40 L

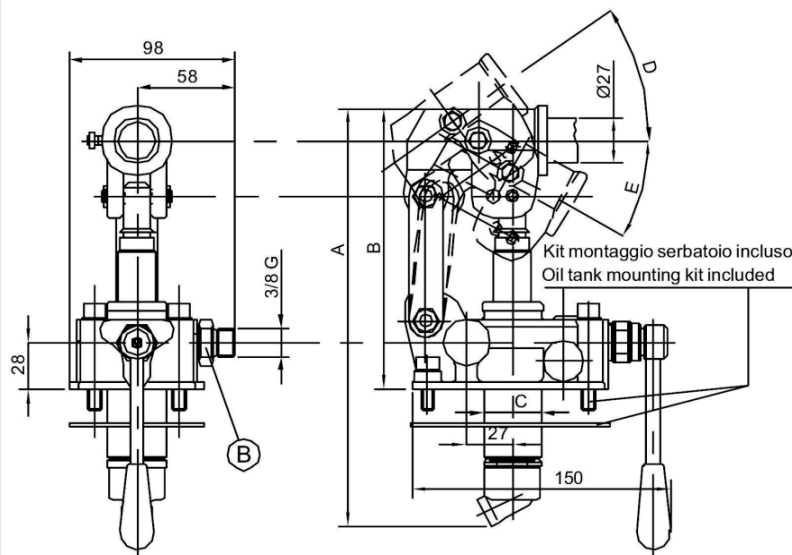

PMSE 20/30/40 L-s



DIAGRAMMA DI CARICO
con spina in E (interasse 51 mm)
LOAD CURVE
pin in E (axle base 51 mm)



POMPA A MANO HAND PUMP

TIPO
TYPE

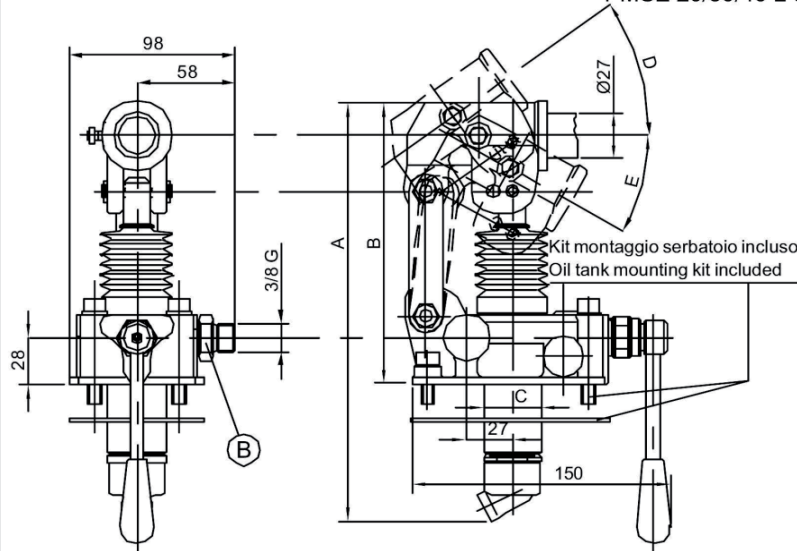
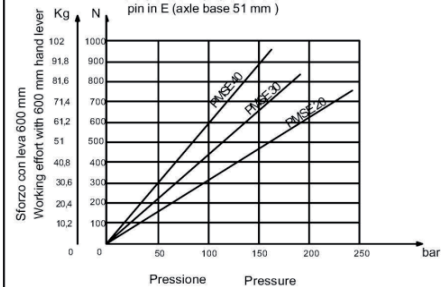
PM 20-30-40

POMPA A MANO PMSE 20-30-40
con leva di scarico e valvola di by pass

HAND PUMP PM 20-30-40
with exhaust lever and pressure relief valve

Pompa a semplice effetto per cilindro a semplice effetto
per montaggio su serbatoio

Single-acting pump for a single-acting cylinder
for assembly on tank

Tipo di pompa Type of pump	Cilindr. (cm ³) Flow (cm ³)	Pressione (Pressure) (bar)		Massa (Kg) Weight (Kg)	Codice senza soffieta. Code without bellows	Codice con soffieta. Code with bellows
		eserciz. (exerciz.)	max.			
PMSE 20	20,527	185	240	3,1	60670005	60670032
PMSE 30	30,262	160	185	3,2	60680005	60680032
PMSE 40	40,290	130	160	3,3	60690005	60690032

TABELLA DIMENSIONI
SIZE TABLE

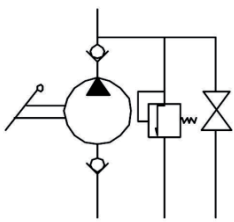

Tipo di pompa Type of pump	A (mm)	B (mm)	C (mm)	D (°)	E (°)
PMSE 20	249	167	34	35	29
PMSE 30	252	167	34	38	26
PMSE 40	252	167	40	38	26

PMSE 20/30/40 L-byA

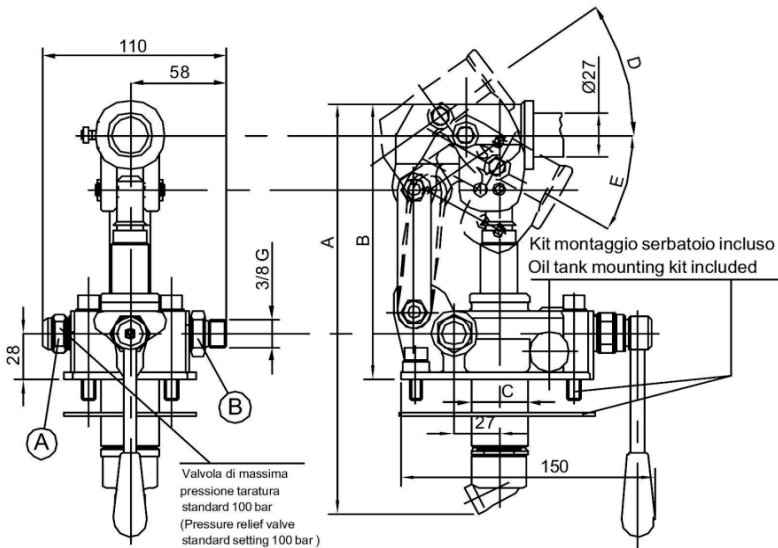

PMSE 20/30/40 L-byA-s



DIAGRAMMA DI CARICO
con spina in E (interasse 51 mm)
LOAD CURVE
pin in E (axle base 51 mm)



POMPA A MANO HAND PUMP

TIPO
TYPE

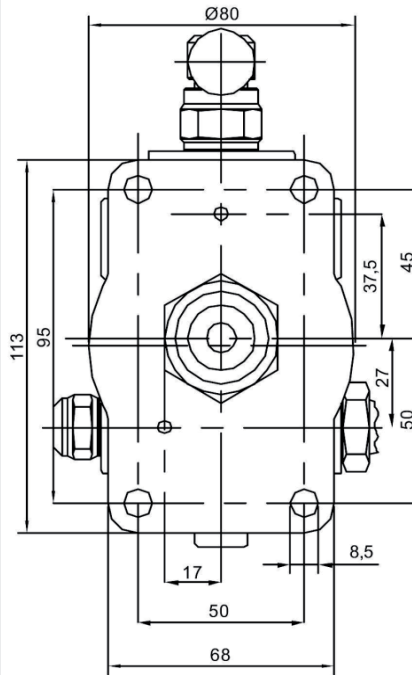
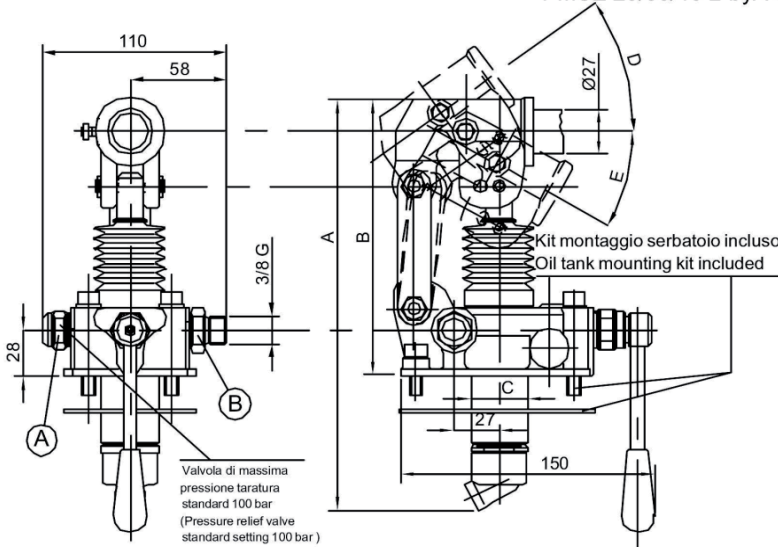
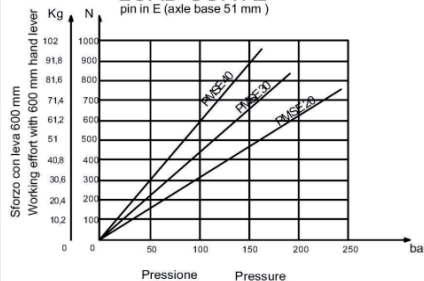
PM2V 5-80

POMPA A MANO PM2V 5-80
con volantino di scarico e comando manuale
esclusione 1° stadio

HAND PUMP PM2V 5-80
with exhaust handwheel and exclusion lever for
the first speed

Pompa bistadio (2 velocità) per un cilindro a semplice effetto.
Fissaggio flangiato per serbatoio.

Hand pump two speed for a single-acting cylinder.
Flanged fixing for oil tank.

Tipo di pompa Type of pump	Cilindr. (Flow) (cm ³)		Pressione (Pressure) (bar)		Massa (Kg) Weight (Kg)	Codice senza soffiet. Code without bellows	Codice con soffiet. Code with bellows
	1° Stadio (first speed)	2° Stadio (second speed)	1° Stadio (first speed)	2° Stadio (second speed)			
PM2V 5-80	5,036	80,588	20	500	6,20	60710000	60710027

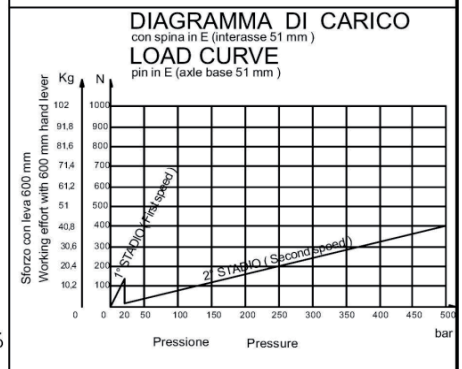
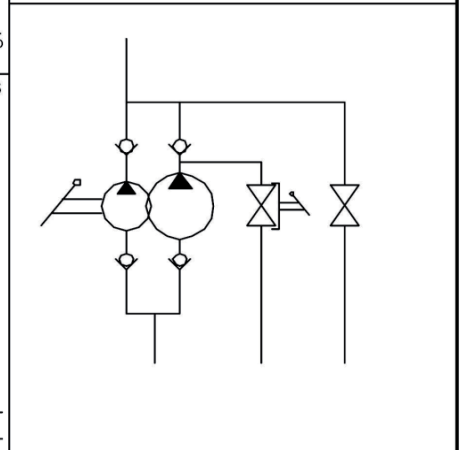
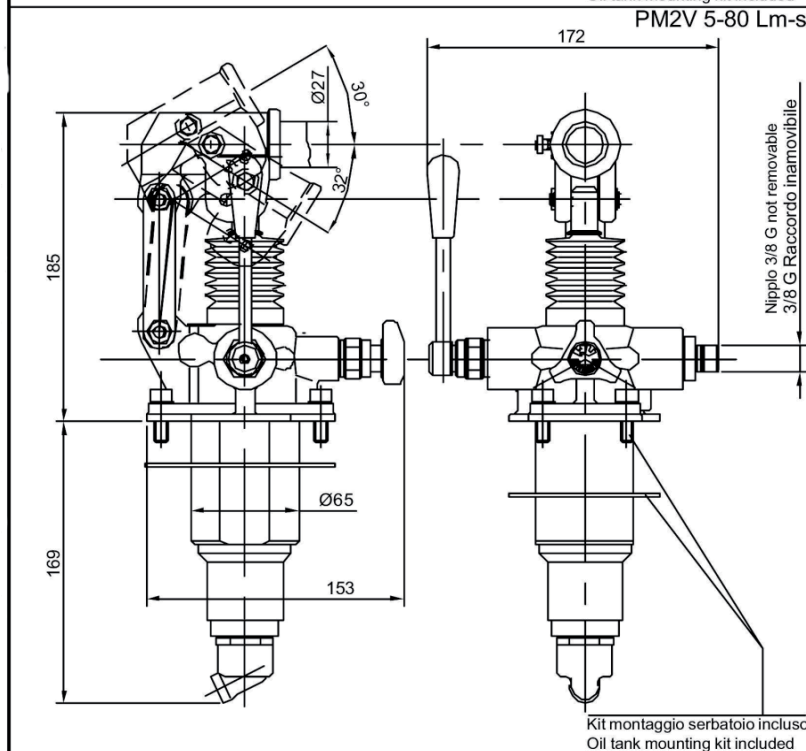
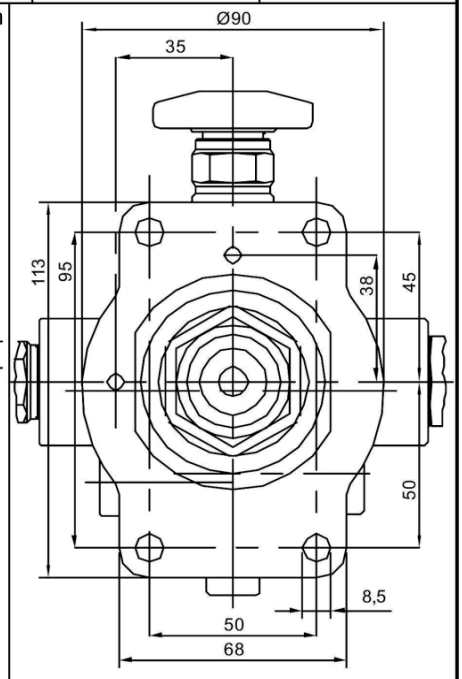
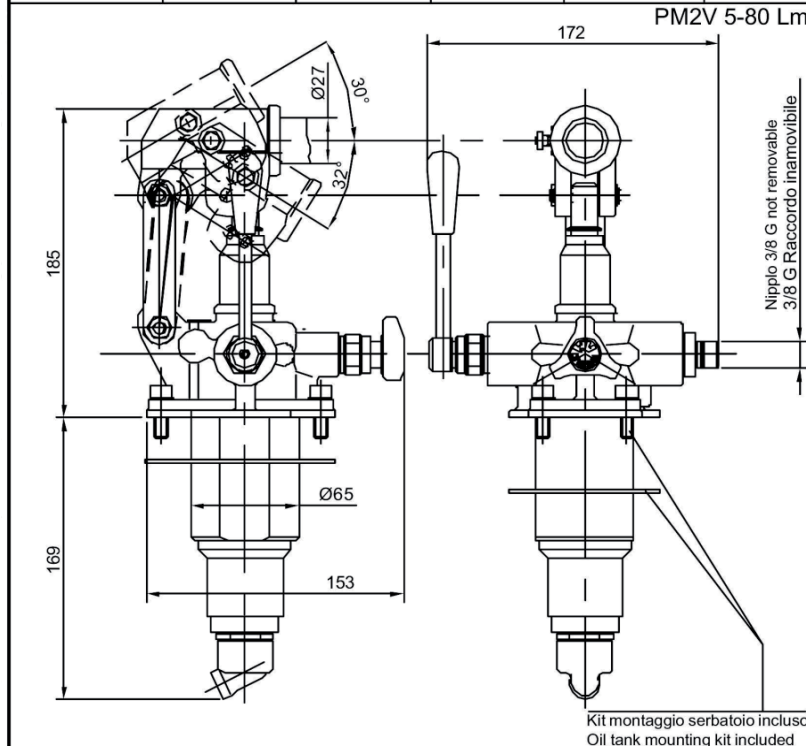

POMPA A MANO HAND PUMP

TIPO
TYPE

PM2V 5-80

POMPA A MANO PM2V 5-80 con volantino di scarico, comando manuale esclusione 1° stadio e valvola di by-pass	HAND PUMP PM2V 5-80 with exhaust handwheel, exclusion lever for the first speed and pressure relief valve
Pompa bistadio (2 velocità) per un cilindro a semplice effetto. Fissaggio flangiato per serbatoio.	Hand pump two speed for a single-acting cylinder. Flanged fixing for oil tank.

Tipo di pompa Type of pump	Cilindr. (Flow) (cm ³)		Pressione (Pressure) (bar)		Massa (Kg) Weight (Kg)	Codice senza soffietti Code without bellows	Codice con soffietti Code with bellows
	1° Stadio (first speed)	2° Stadio (second speed)	1° Stadio (first speed)	2° Stadio (second speed)			
PM2V 5-80	5,036	80,588	20	500	6,20	60710001	60710028

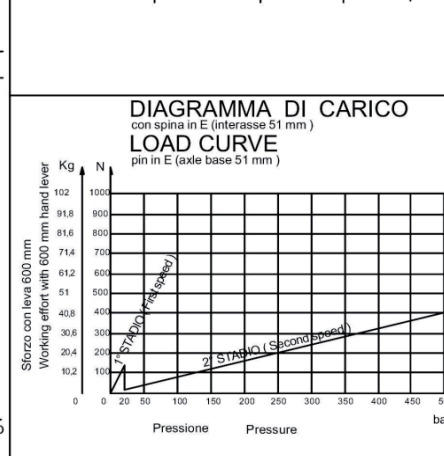
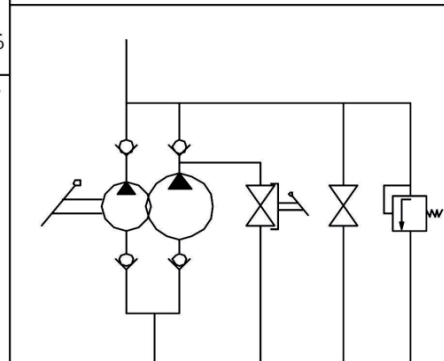
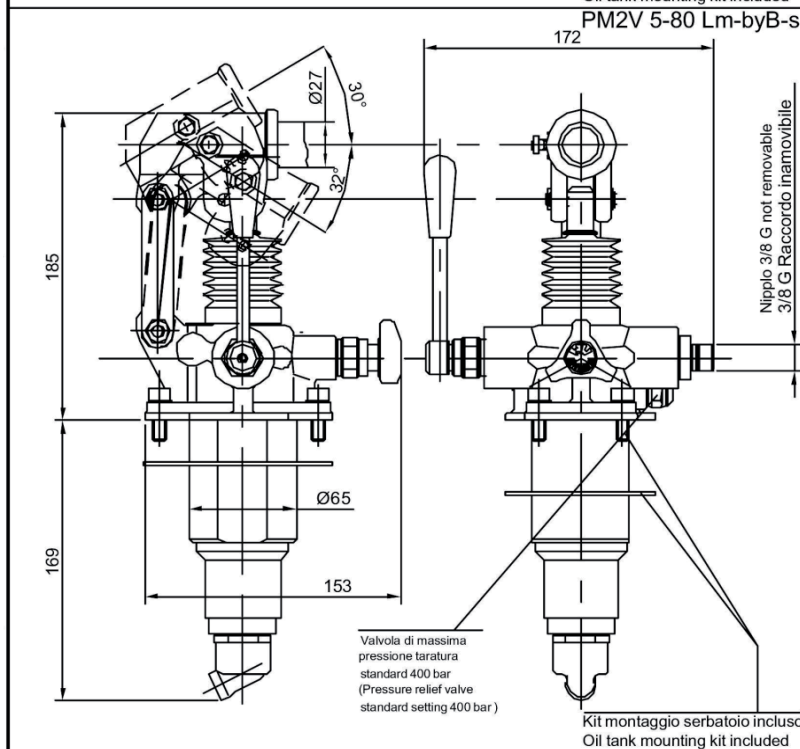
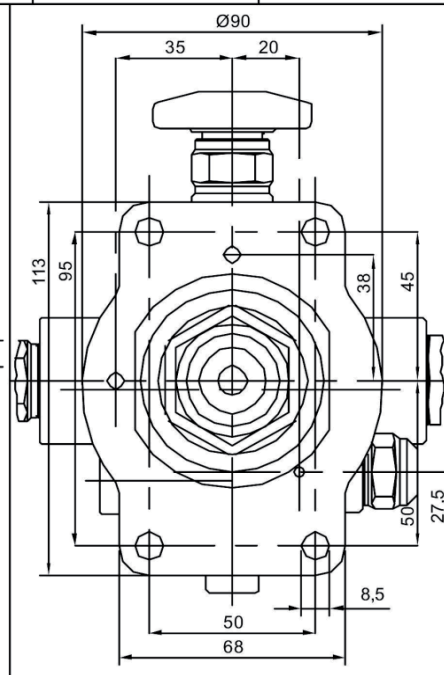
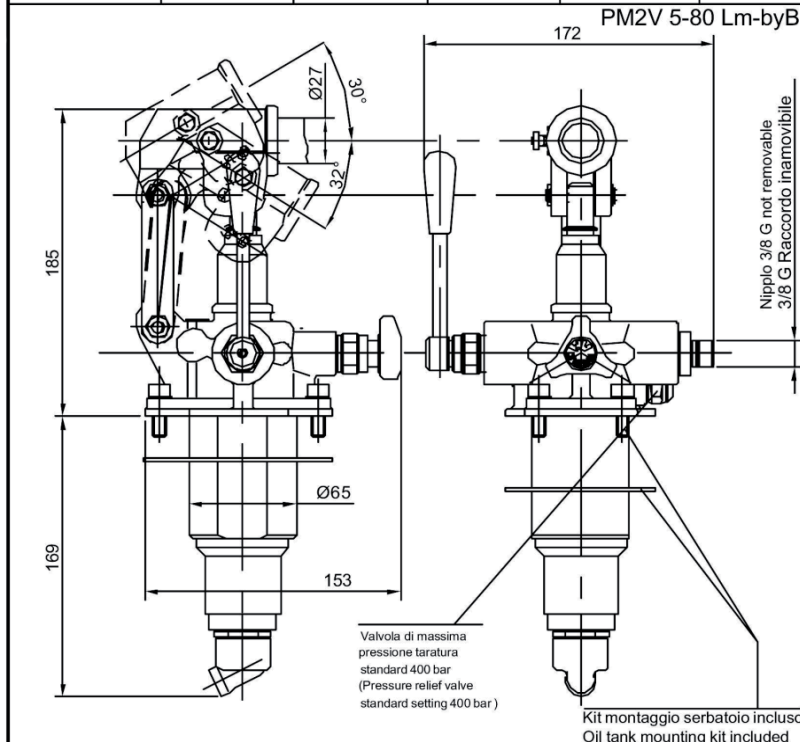

POMPA A MANO HAND PUMP

TIPO
TYPE

PM2V 5-80

POMPA A MANO PM2V 5-80 con volantino di scarico, comando manuale esclusione 1° stadio e predisposizione manometro	HAND PUMP PM2V 5-80 with exhaust handwheel, exclusion lever for the first speed and pressure-gauge predisposition
Pompa bistadio (2 velocità) per un cilindro a semplice effetto. Fissaggio flangiato per serbatoio.	Hand pump two speed for a single-acting cylinder. Flanged fixing for oil tank.

Tipo di pompa Type of pump	Cilindr. (Flow) (cm ³)		Pressione (Pressure) (bar)		Massa (Kg) Weight (Kg)	Codice senza soffietti Code without bellows	Codice con soffietti Code with bellows
	1° Stadio (first speed)	2° Stadio (second speed)	1° Stadio (first speed)	2° Stadio (second speed)			
PM2V 5-80	5,036	80,588	20	500	6,20	60710002	60710029



DIAGRAMMA DI CARICO
con spina in E (interasse 51 mm)
LOAD CURVE
pin in E (axle base 51 mm)



POMPA A MANO HAND PUMP

TIPO
TYPE

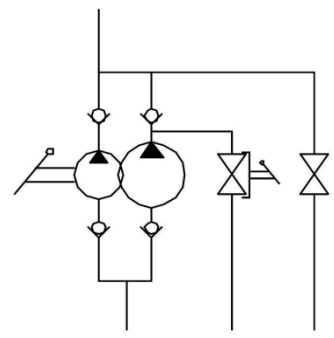
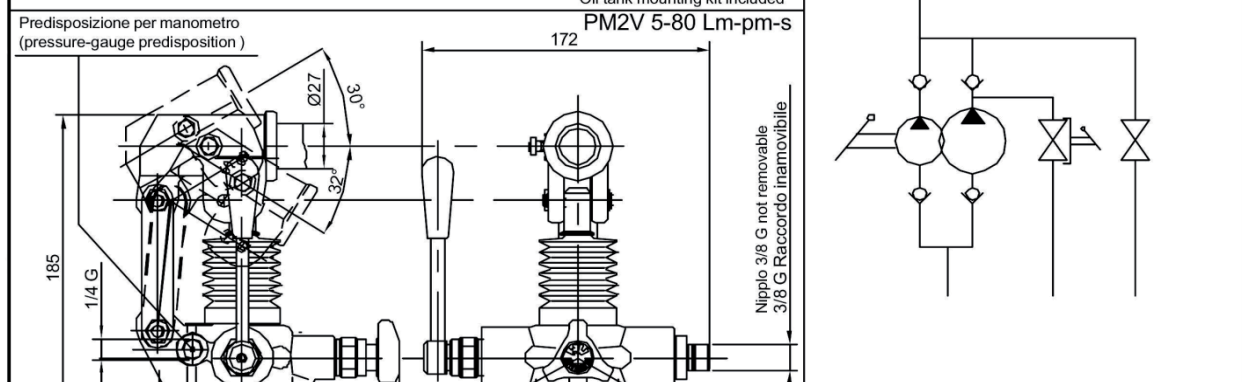
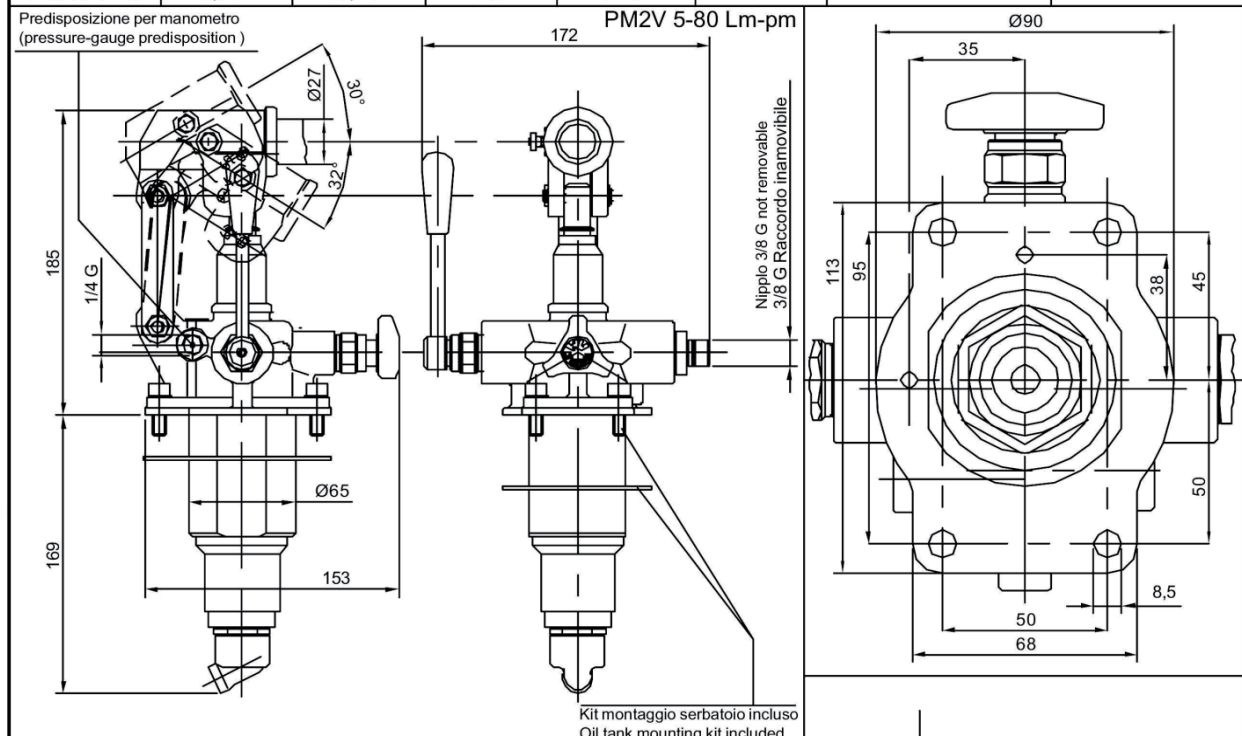
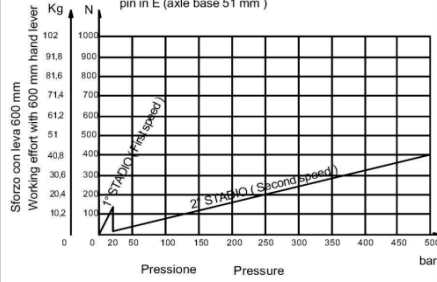
PM2V 5-80

POMPA A MANO PM2V 5-80 con volantino di scarico, comando manuale esclusione 1° stadio e Manometro	HAND PUMP PM2V 5-80 with exhaust handwheel, exclusion lever for the first speed and pressure-gauge
Pompa bistadio (2 velocità) per un cilindro a semplice effetto. Fissaggio flangiato per serbatoio.	Hand pump two speed for a single-acting cylinder. Flanged fixing for oil tank.

Tipo di pompa Type of pump	Cilindr. (Flow) (cm ³)		Pressione (Pressure) (bar)		Massa (Kg) Weight (Kg)	Codice senza soffiet. Code without bellows	Codice con soffiet. Code with bellows
	1° Stadio (first speed)	2° Stadio (second speed)	1° Stadio (first speed)	2° Stadio (second speed)			
PM2V 5-80	5,036	80,588	20	500	6,20	60710003	60710030

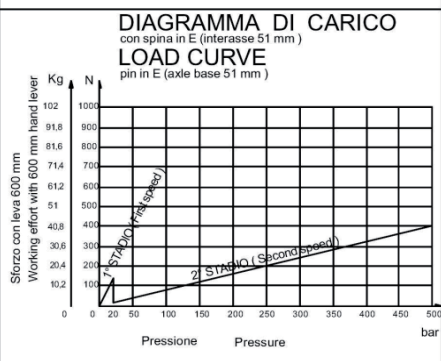
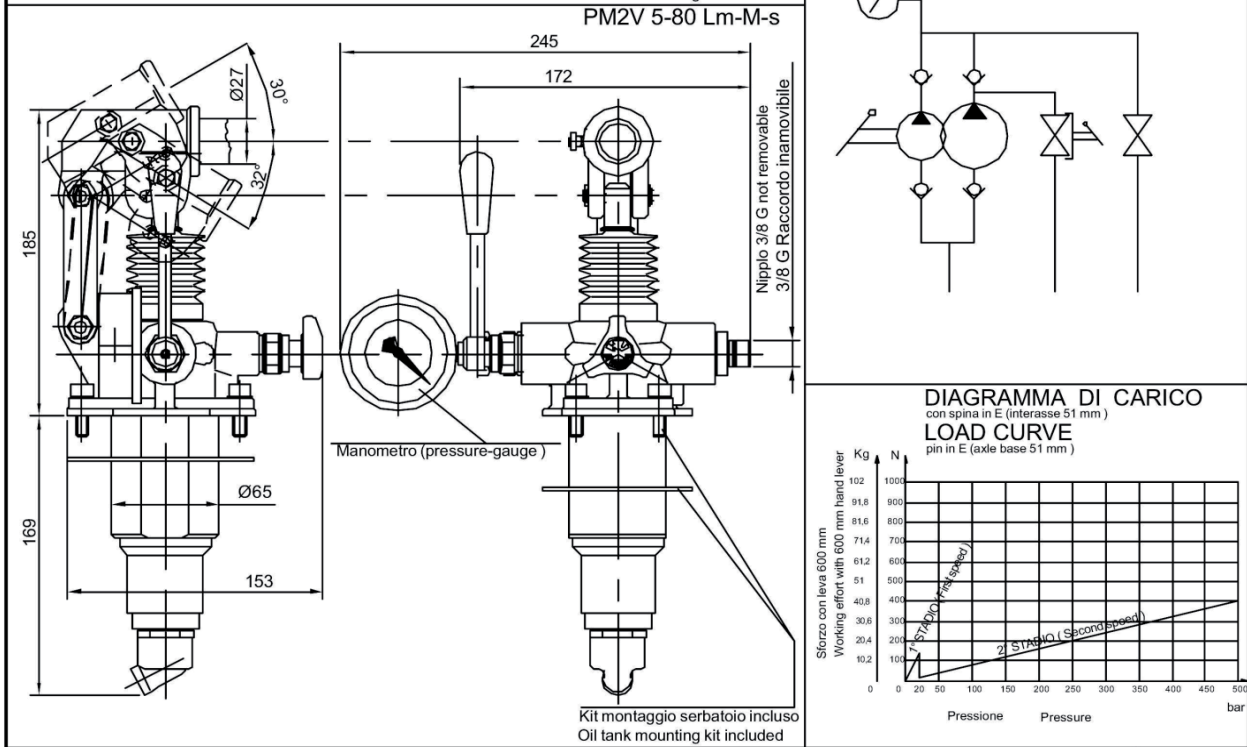
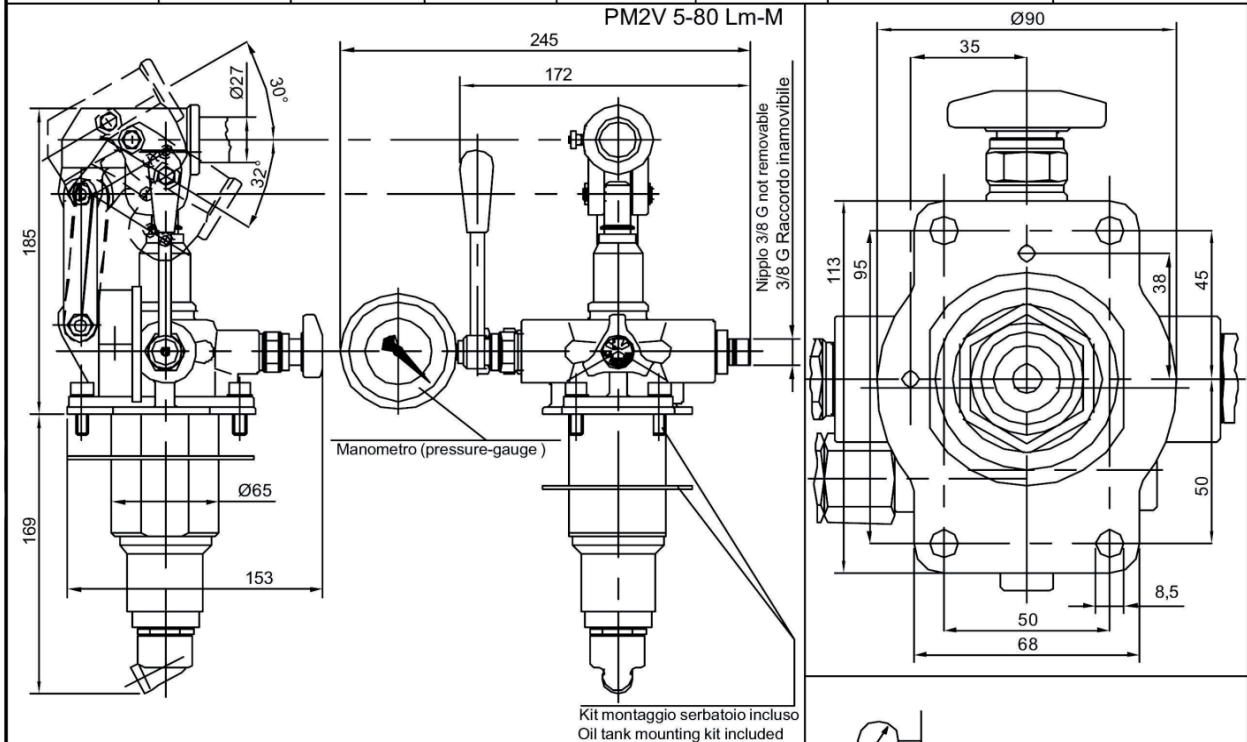

POMPA A MANO HAND PUMP

TIPO
TYPE

PM2V 5-80

POMPA A MANO PM2V 5-80
con volantino di scarico, comando manuale
esclusione 1° stadio, valvola di by-pass e
predisposizione manometro

HAND PUMP PM2V 5-80
with exhaust handwheel, exclusion lever for
the first speed, pressure relief valve and
pressure-gauge predisposition

Pompa bistadio (2 velocità) per un cilindro a semplice effetto.
Fissaggio flangiato per serbatoio.

Hand pump two speed for a single-acting cylinder.
Flanged fixing for oil tank.

Tipo di pompa Type of pump	Cilindr. (Flow) (cm ³)		Pressione (Pressure) (bar)		Massa (Kg) Weight (Kg)	Codice senza soffietti Code without bellows	Codice con soffietti Code with bellows
	1° Stadio (first speed)	2° Stadio (second speed)	1° Stadio (first speed)	2° Stadio (second speed)			
PM2V 5-80	5,036	80,588	20	500	6,20	60710004	60710031

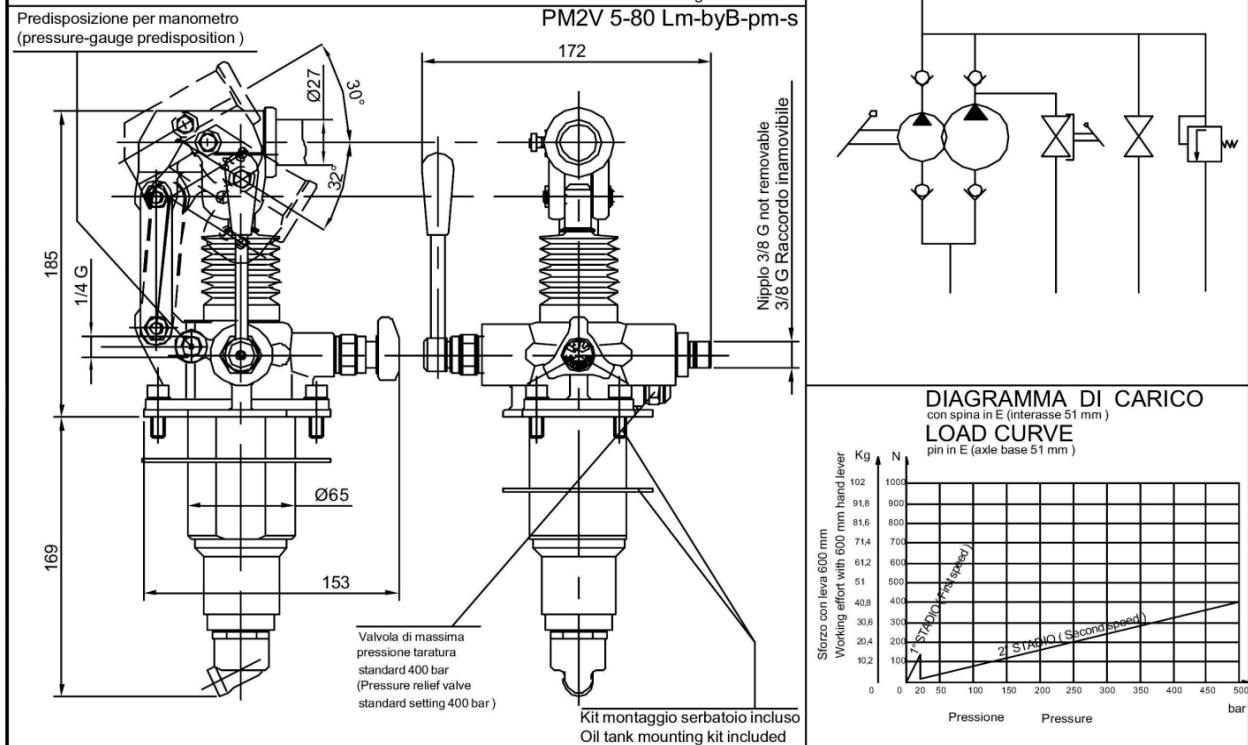
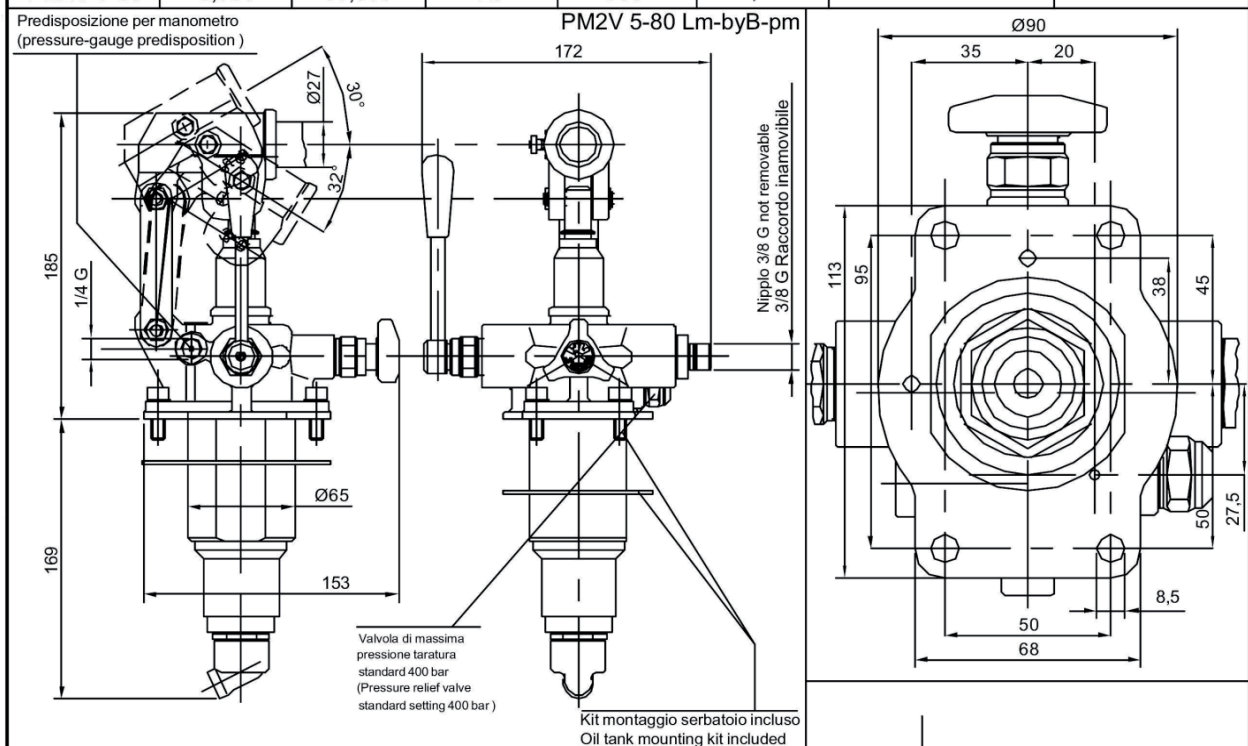

POMPA A MANO HAND PUMP

TIPO
TYPE

PM2V 5-80

POMPA A MANO PM2V 5-80
con volantino di scarico, comando manuale
esclusione 1° stadio, valvola di by-pass e
Manometro

Pompa bistadio (2 velocità) per un cilindro a semplice effetto.
Fissaggio flangiato per serbatoio.

HAND PUMP PM2V 5-80
with exhaust handwheel, exclusion lever for
the first speed, pressure relief valve and
pressure-gauge

Hand pump two speed for a single-acting cylinder.
Flanged fixing for oil tank.

Tipo di pompa Type of pump	Cilindr. (Flow) (cm ³)		Pressione (Pressure) (bar)		Massa (Kg) Weight (Kg)	Codice senza soffiet. Code without bellows	Codice con soffiet. Code with bellows
	1° Stadio (first speed)	2° Stadio (second speed)	1° Stadio (first speed)	2° Stadio (second speed)			
PM2V 5-80	5,036	80,588	20	500	6,20	60710005	60710032

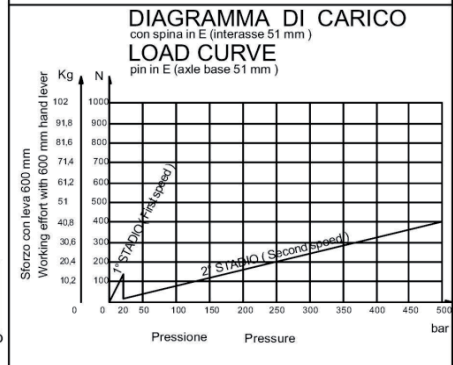
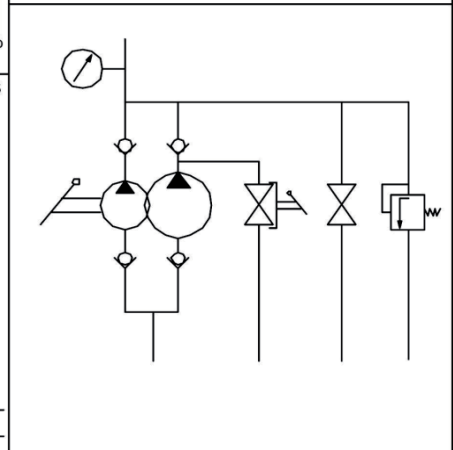
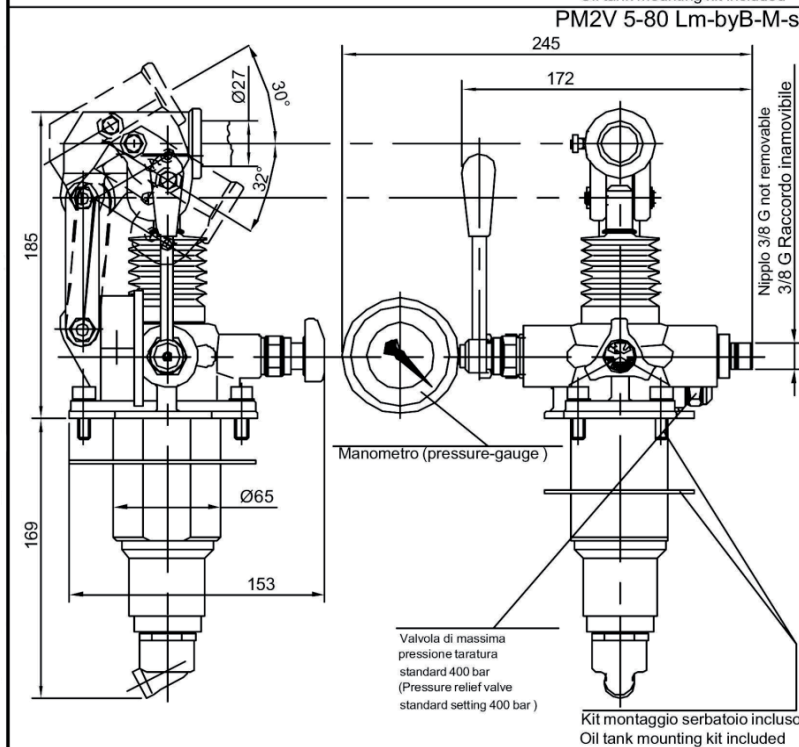
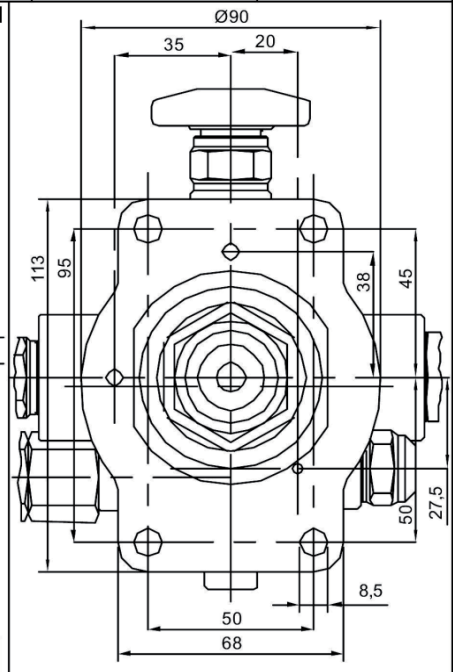
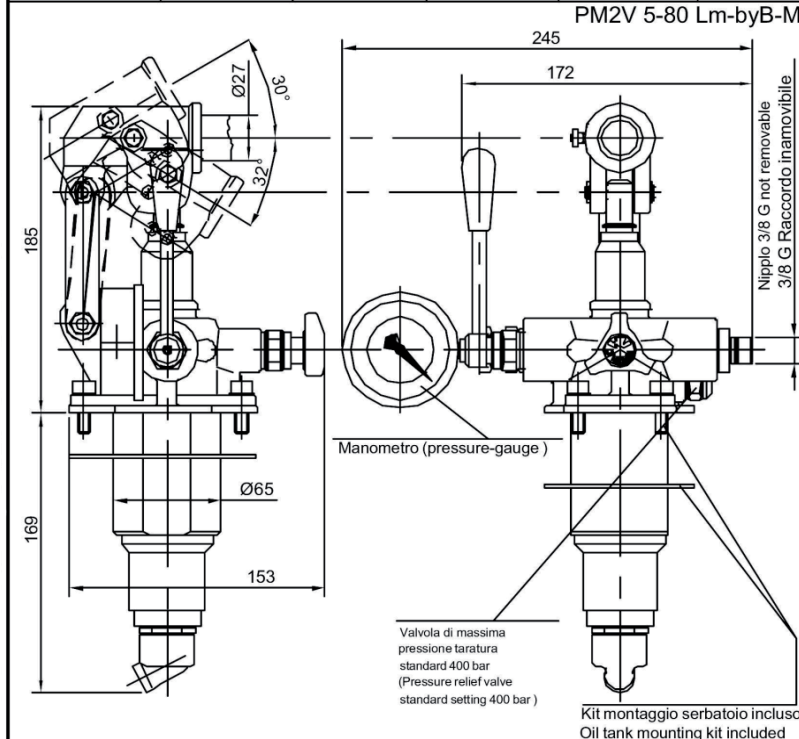

POMPA A MANO HAND PUMP

TIPO
TYPE

PM2V 5-80

POMPA A MANO PM2V 5-80
con volantino di scarico e comando automatico
esclusione 1° stadio

HAND PUMP PM2V 5-80
with exhaust handwheel and exclusion automatic
control for the first speed

Pompa bistadio (2 velocità) per un cilindro a semplice effetto.
Fissaggio flangiato per serbatoio.

Hand pump two speed for a single-acting cylinder.
Flanged fixing for oil tank.

Tipo di pompa Type of pump	Cilindr. (Flow) (cm ³)		Pressione (Pressure) (bar)		Massa (Kg) Weight (Kg)	Codice senza soffiet. Code without bellows	Codice con soffiet. Code with bellows
	1° Stadio (first speed)	2° Stadio (second speed)	1° Stadio (first speed)	2° Stadio (second speed)			
PM2V 5-80	5,036	80,588	20	500	6,20	60710006	60710033

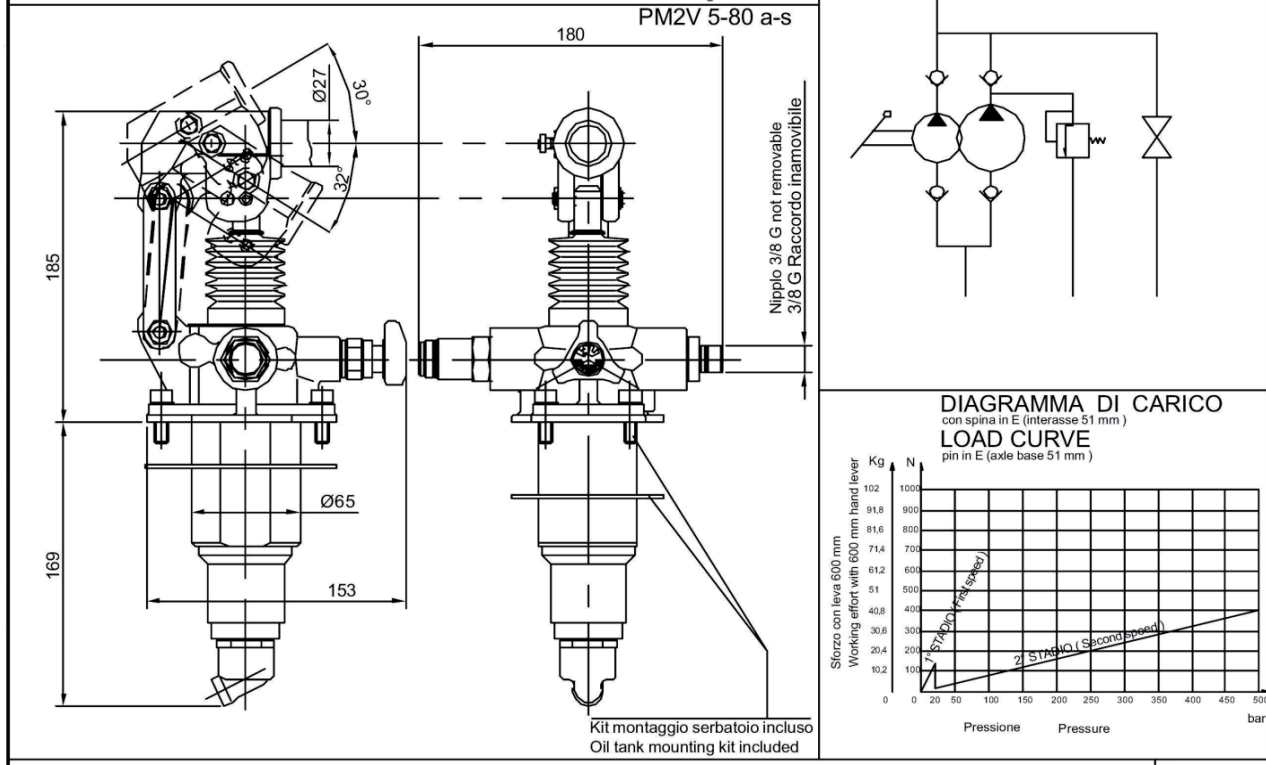
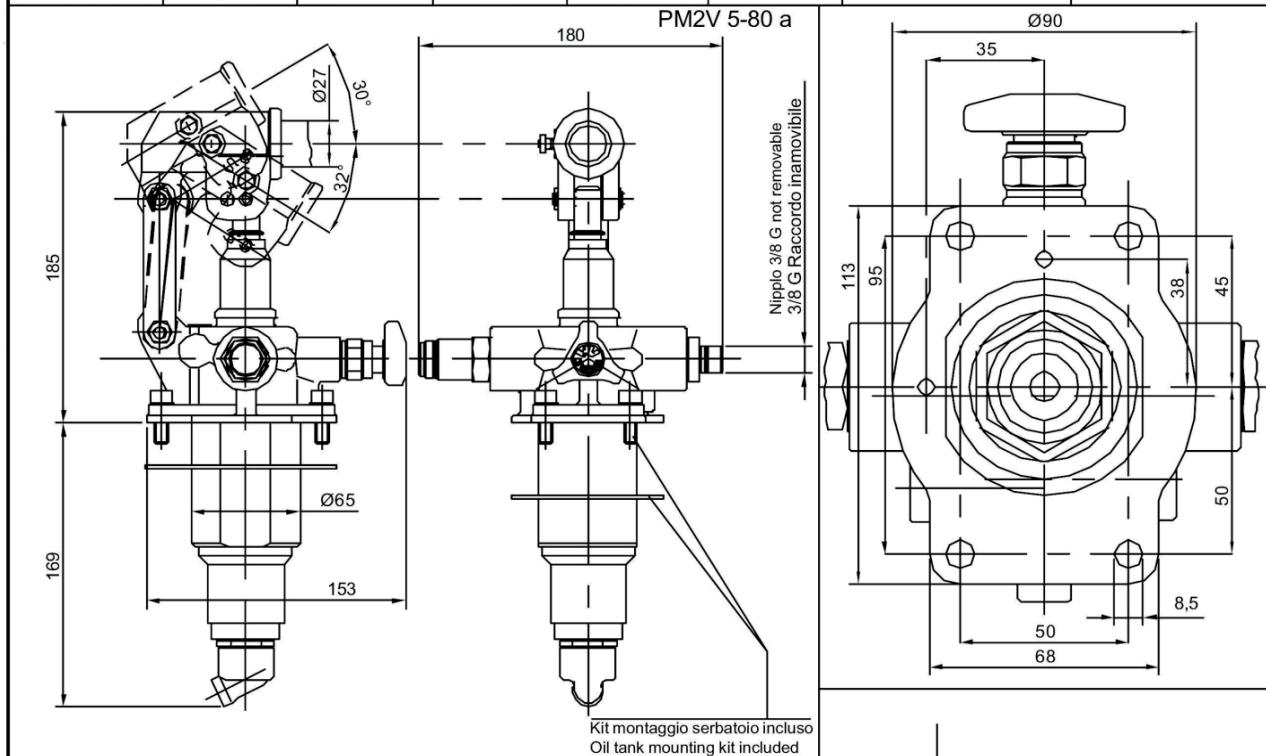

POMPA A MANO HAND PUMP

TIPO
TYPE

PM2V 5-80

POMPA A MANO PM2V 5-80
con volantino di scarico, comando automatico
esclusione 1° stadio e valvola di by-pass

HAND PUMP PM2V 5-80
with exhaust handwheel, exclusion automatic
control for the first speed and pressure relief valve

Pompa bistadio (2 velocità) per un cilindro a semplice effetto.
Fissaggio flangiato per serbatoio.

Hand pump two speed for a single-acting cylinder.
Flanged fixing for oil tank.

Tipo di pompa Type of pump	Cilindr. (Flow) (cm ³)		Pressione (Pressure) (bar)		Massa (Kg) Weight (Kg)	Codice senza soffietti Code without bellows	Codice con soffietti Code with bellows
	1° Stadio (first speed)	2° Stadio (second speed)	1° Stadio (first speed)	2° Stadio (second speed)			
PM2V 5-80	5,036	80,588	20	500	6,20	60710007	60710034

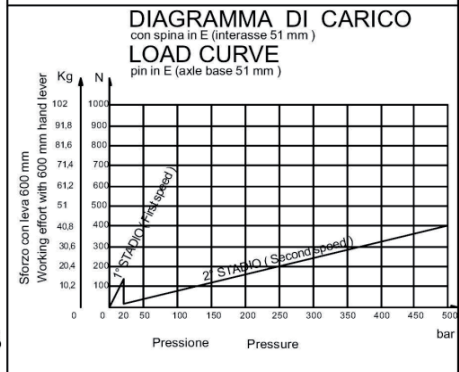
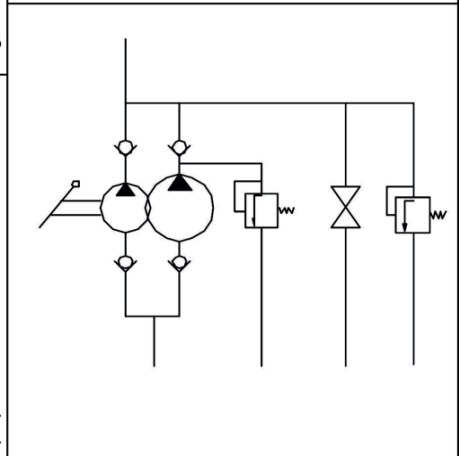
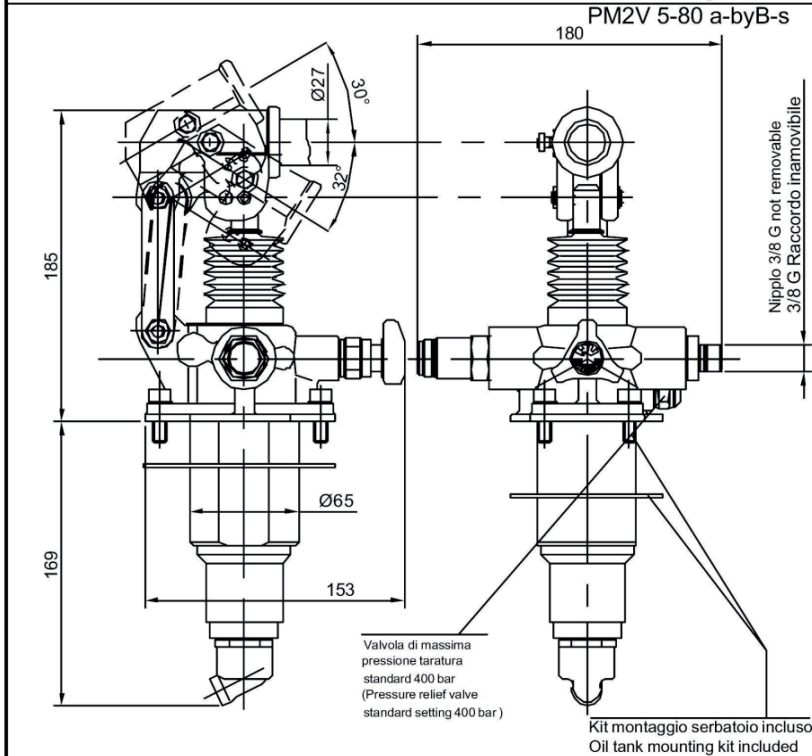
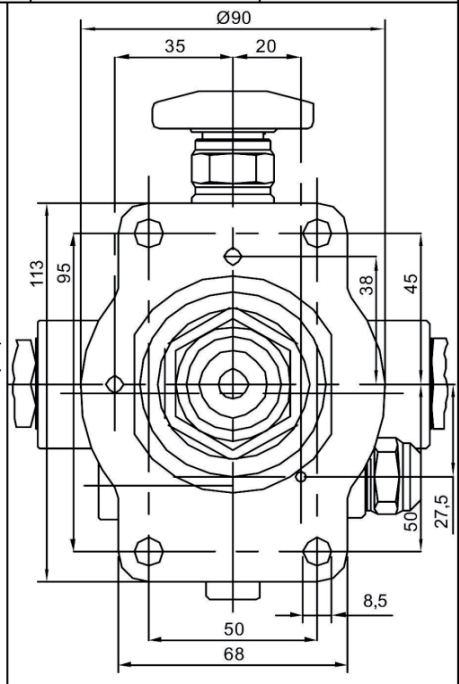
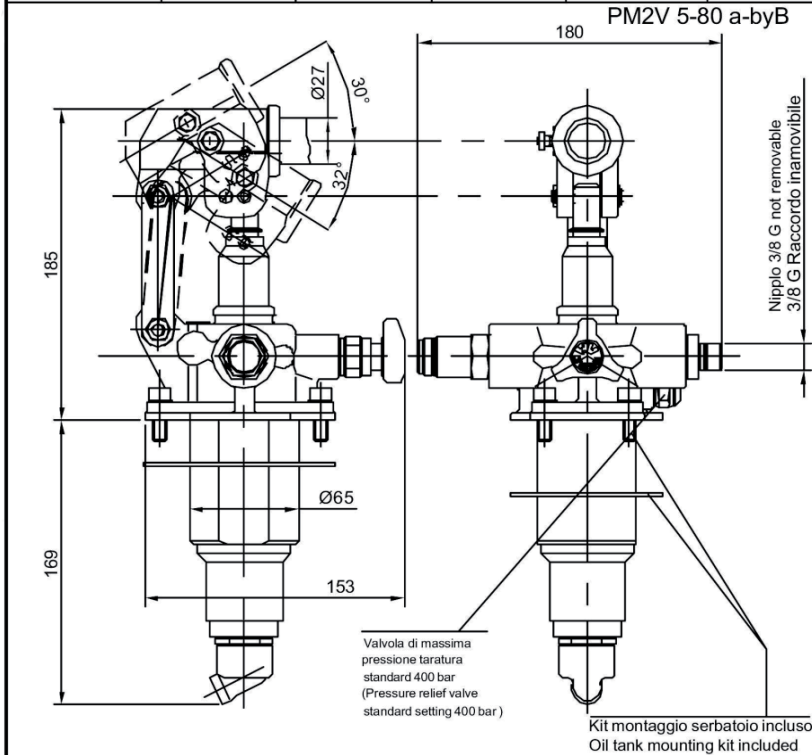

POMPA A MANO HAND PUMP

TIPO
TYPE

PM2V 5-80

POMPA A MANO PM2V 5-80 con volantino di scarico, comando automatico esclusione 1° stadio e predisposizione manometro	HAND PUMP PM2V 5-80 with exhaust handwheel, exclusion automatic control for the first speed and pressure-gauge predisposition
Pompa bistadio (2 velocità) per un cilindro a semplice effetto. Fissaggio flangiato per serbatoio.	Hand pump two speed for a single-acting cylinder. Flanged fixing for oil tank.

Tipo di pompa Type of pump	Cilindr. (Flow) (cm ³)		Pressione (Pressure) (bar)		Massa (Kg) Weight (Kg)	Codice senza soffiet. Code without bellows	Codice con soffiet. Code with bellows
	1° Stadio (first speed)	2° Stadio (second speed)	1° Stadio (first speed)	2° Stadio (second speed)			
PM2V 5-80	5,036	80,588	20	500	6,20	60710008	60710035

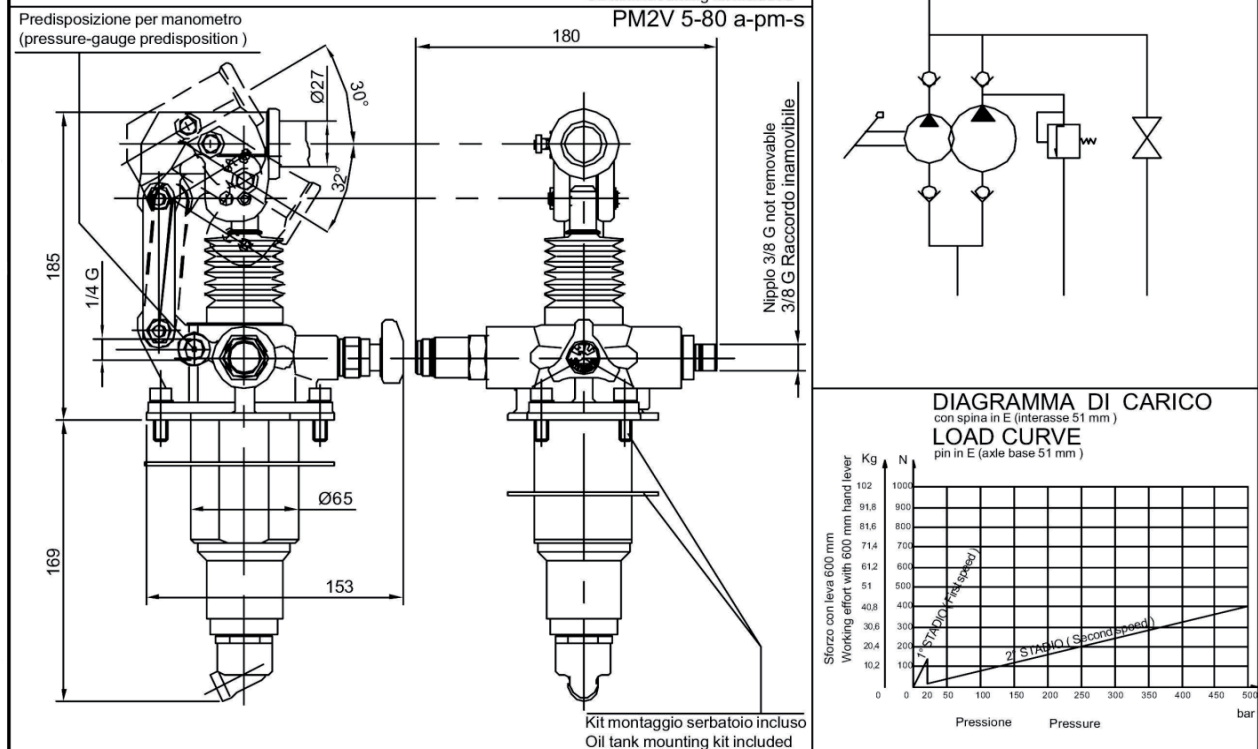
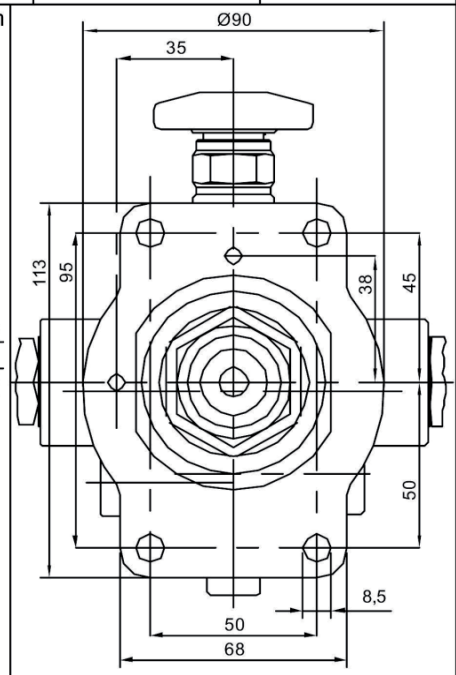
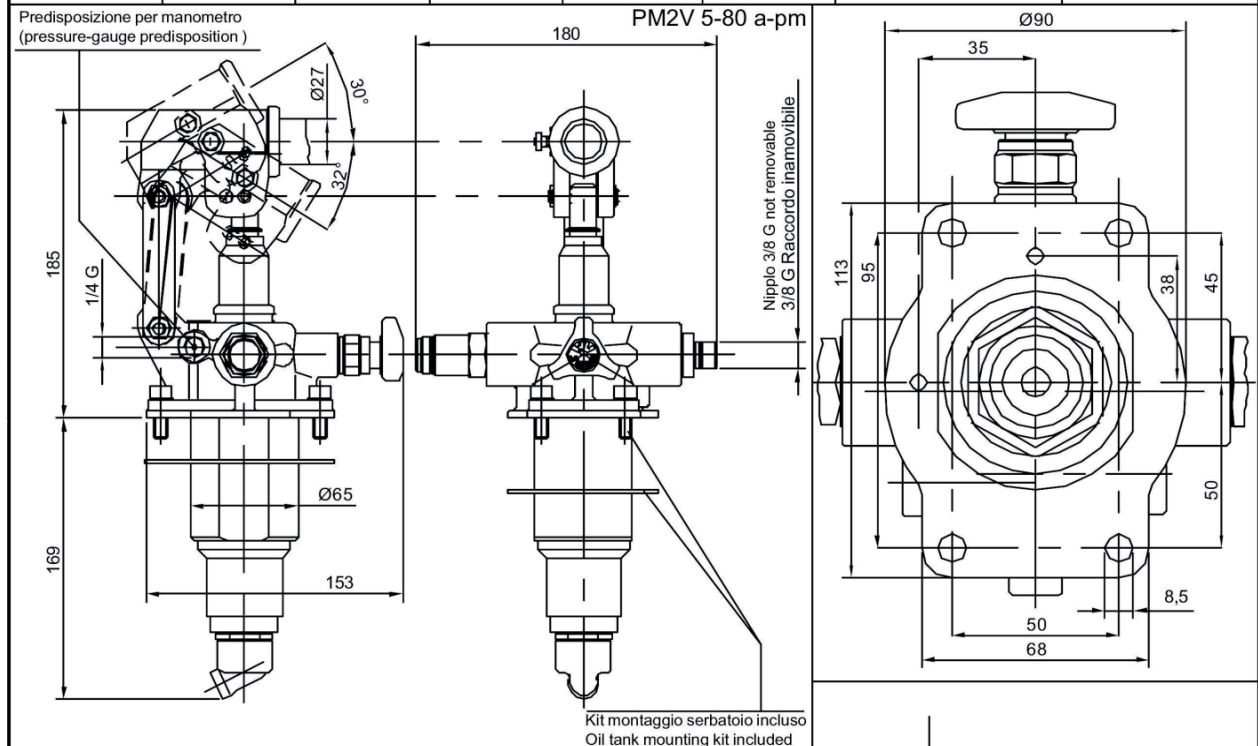

POMPA A MANO HAND PUMP

TIPO
TYPE

PM2V 5-80

POMPA A MANO PM2V 5-80 con volantino di scarico, comando automatico esclusione 1° stadio e Manometro	HAND PUMP PM2V 5-80 with exhaust handwheel, exclusion automatic control for the first speed and pressure-gauge
Pompa bistadio (2 velocità) per un cilindro a semplice effetto. Fissaggio flangiato per serbatoio.	Hand pump two speed for a single-acting cylinder. Flanged fixing for oil tank.

Tipo di pompa Type of pump	Cilindr. (Flow) (cm ³)		Pressione (Pressure) (bar)		Massa (Kg) Weight (Kg)	Codice senza soffiet. Code without bellows	Codice con soffiet. Code with bellows
	1° Stadio (first speed)	2° Stadio (second speed)	1° Stadio (first speed)	2° Stadio (second speed)			
PM2V 5-80	5,036	80,588	20	500	6,20	60710009	60710036

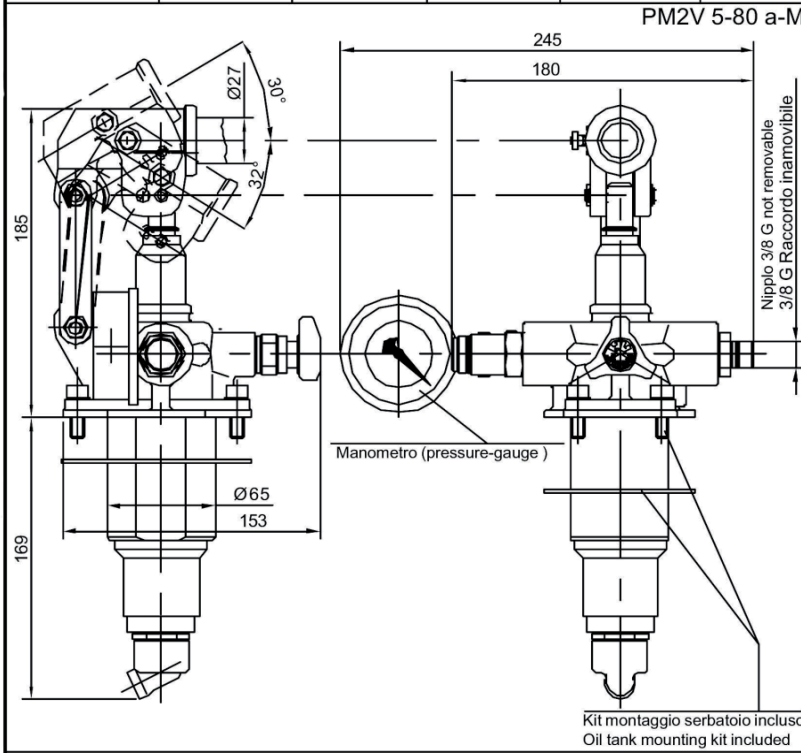

Kit montaggio serbatoio incluso
Oil tank mounting kit included

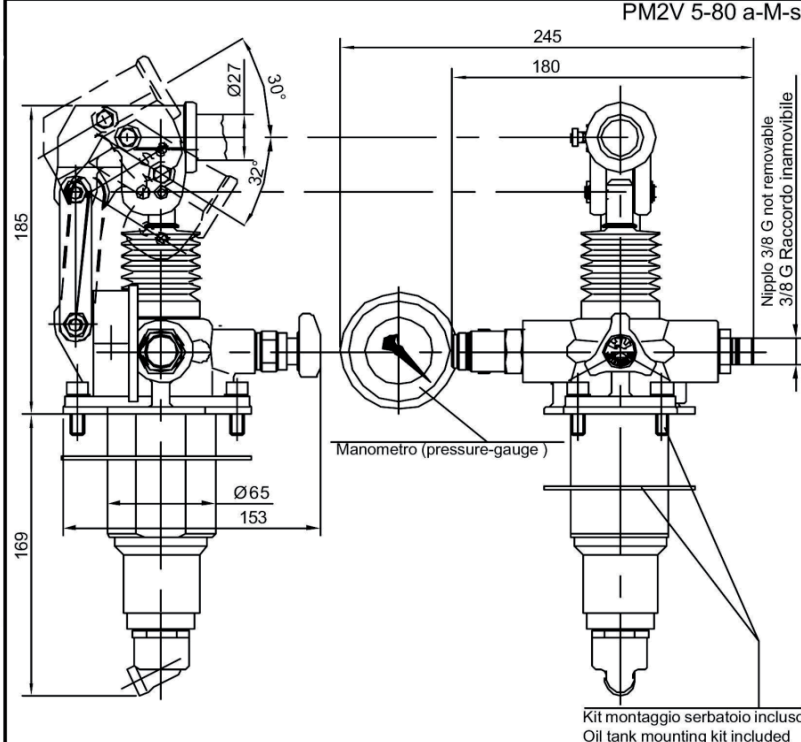
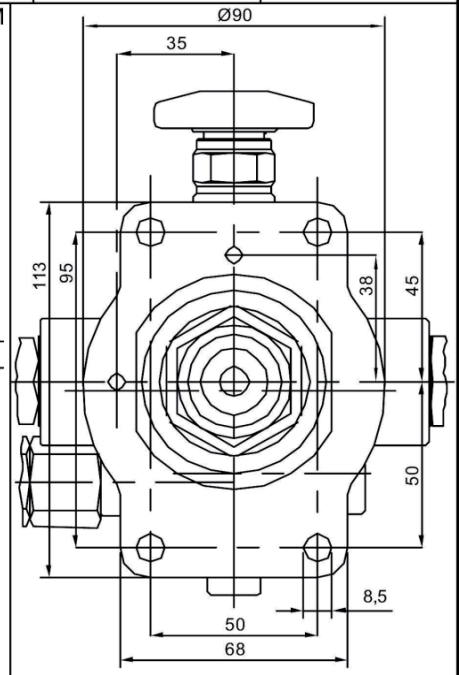

Kit montaggio serbatoio incluso
Oil tank mounting kit included

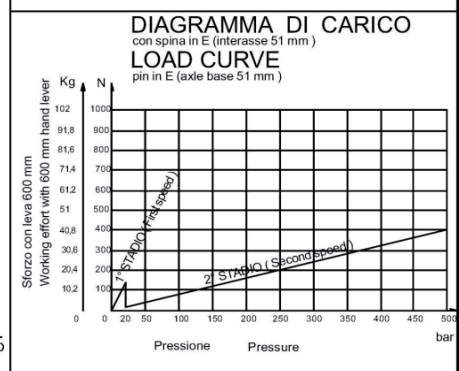
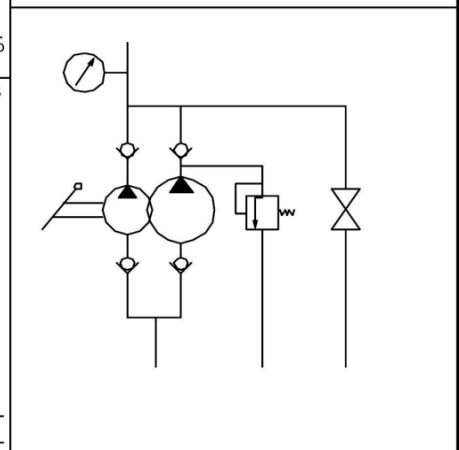

POMPA A MANO HAND PUMP

TIPO
TYPE

PM2V 5-80

POMPA A MANO PM2V 5-80
con volantino di scarico, comando automatico
esclusione 1° stadio, valvola di by-pass e
predisposizione manometro

Pompa bistadio (2 velocità) per un cilindro a semplice effetto.
Fissaggio flangiato per serbatoio.

HAND PUMP PM2V 5-80

with exhaust handwheel, exclusion automatic
control for the first speed, pressure relief valve
and pressure-gauge predisposition

Hand pump two speed for a single-acting cylinder.
Flanged fixing for oil tank.

Tipo di pompa Type of pump	Cilindr. (Flow) (cm ³)		Pressione (Pressure) (bar)		Massa (Kg) Weight (Kg)	Codice senza soffiet. Code without bellows	Codice con soffiet. Code with bellows
	1° Stadio (first speed)	2° Stadio (second speed)	1° Stadio (first speed)	2° Stadio (second speed)			
PM2V 5-80	5,036	80,588	20	500	6,20	60710010	60710037

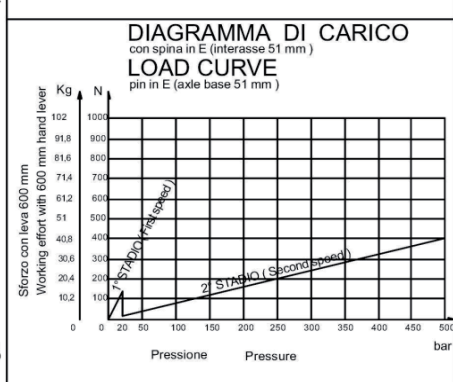
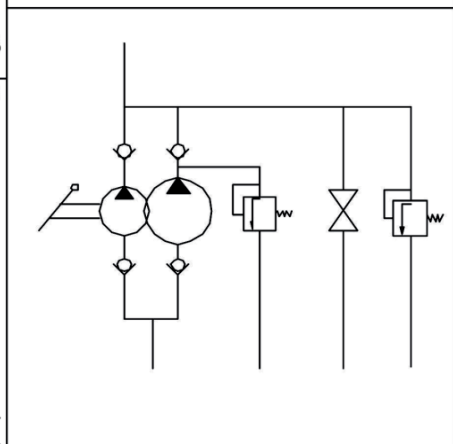
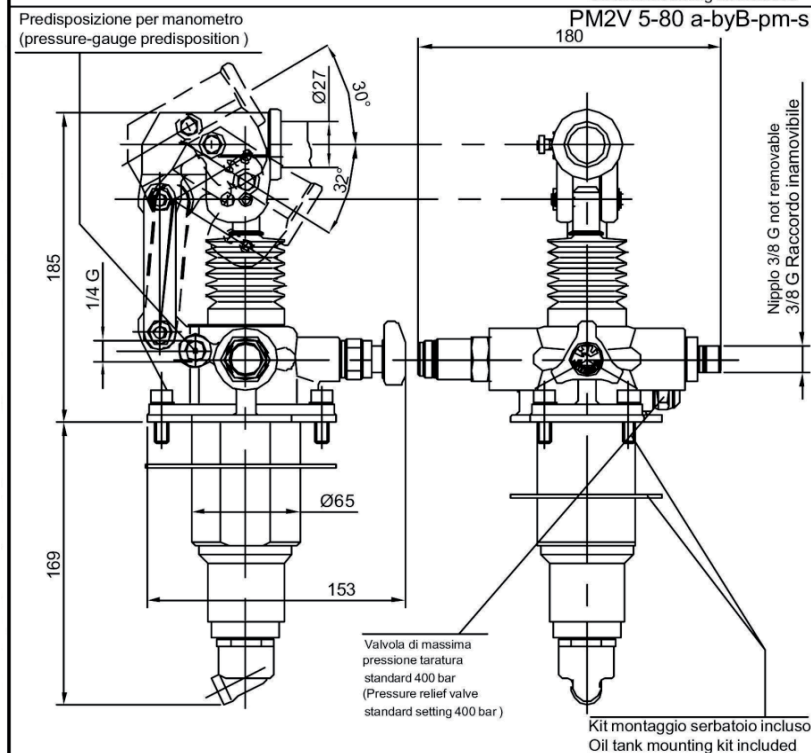
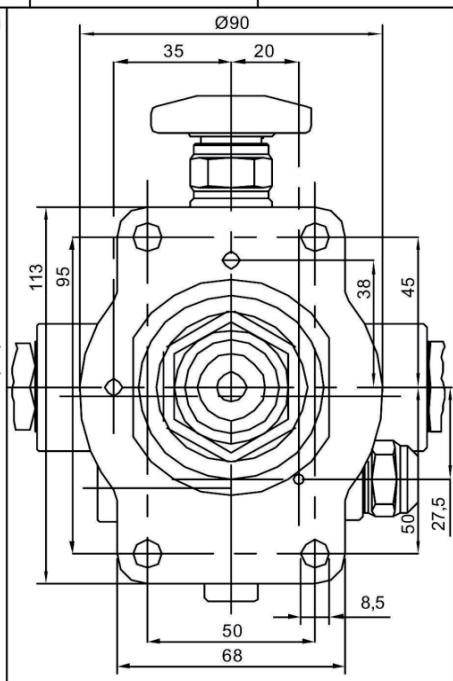
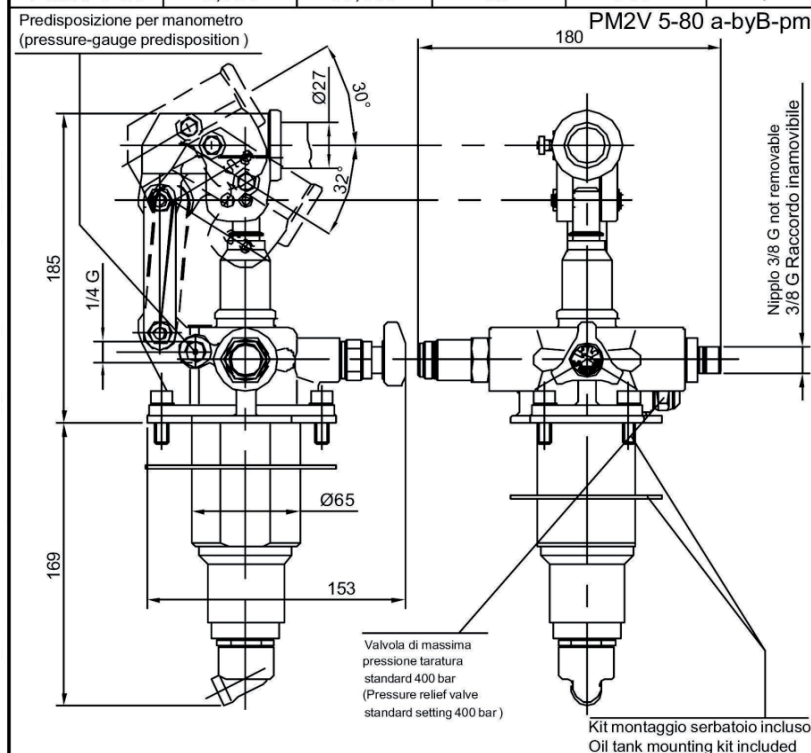

POMPA A MANO HAND PUMP

TIPO
TYPE

PM2V 5-80

POMPA A MANO PM2V 5-80
con volantino di scarico, comando automatico
esclusione 1° stadio, valvola di by-pass e
manometro

Pompa bistadio (2 velocità) per un cilindro a semplice effetto.
Fissaggio flangiato per serbatoio.

HAND PUMP PM2V 5-80
with exhaust handwheel, exclusion automatic
control for the first speed, pressure relief valve
and pressure-gauge

Hand pump two speed for a single-acting cylinder.
Flanged fixing for oil tank.

Tipo di pompa Type of pump	Cilindr. (Flow) (cm ³)		Pressione (Pressure) (bar)		Massa (Kg) Weight (Kg)	Codice senza soffiet. Code without bellows	Codice con soffiet. Code with bellows
	1° Stadio (first speed)	2° Stadio (second speed)	1° Stadio (first speed)	2° Stadio (second speed)			
PM2V 5-80	5,036	80,588	20	500	6,20	60710011	60710038

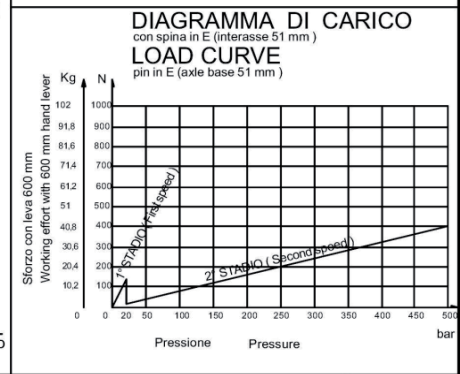
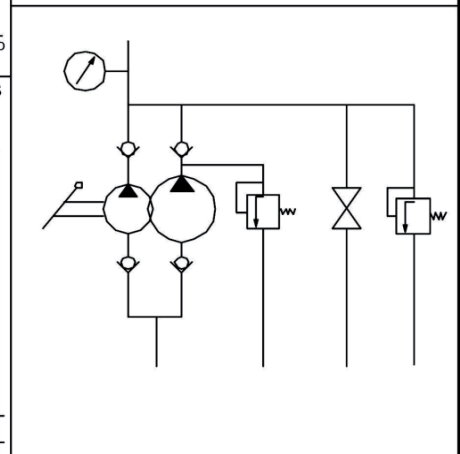
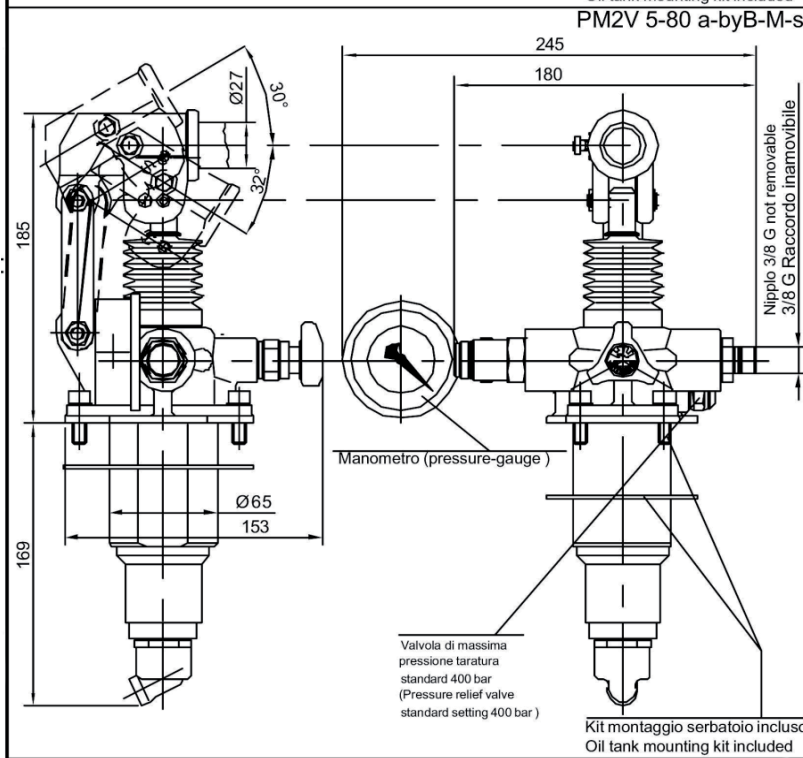
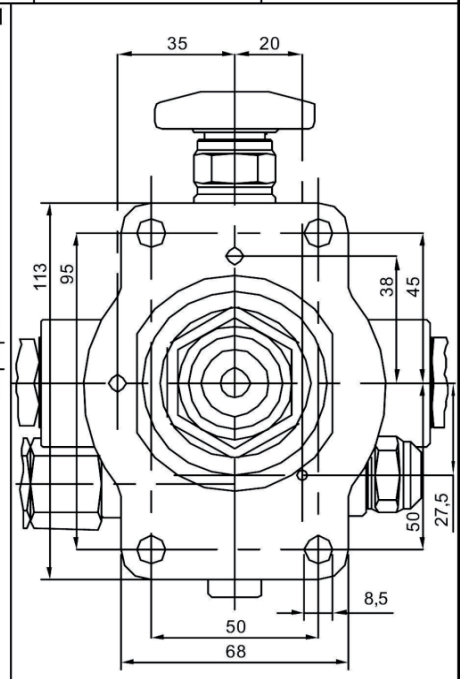
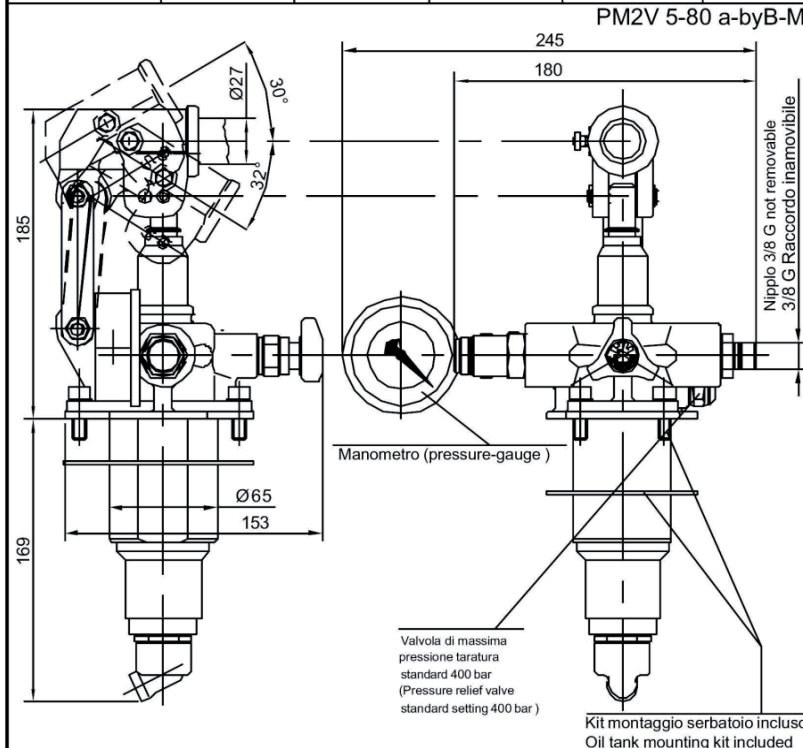

LEVE PER POMPE A MANO LEVERS FOR HAND PUMPS

Tipo di leva Type of lever	CODICE CODE	S (mm)	L (mm)	Massa (Kg) Weight (Kg)	Zincatura Zinc-plating	Leva per tipo di pompa (Lever for type of pump)
L 20x500 zb-d	68000000	20	500	0,4	Bianca (White)	PMSE 8-15
L 27x330 zb-d	68000005	27	330	0,5	Bianca (White)	PM/PMD/PMDVB 12-25-45 PMO 50-70 PMP 20 PMSE 20-30-40 PM2V 5-80
L 27x400 zb-d	68000007	27	400	0,6	Bianca (White)	PM/PMD/PMDVB 12-25-45 PMO 50-70 PMP 20 PMSE 20-30-40 PM2V 5-80
L 27x600 zb-d	68000009	27	600	0,9	Bianca (White)	PM/PMD/PMDVB 12-25-45 PMO 50-70 PMP 20 PMSE 20-30-40 PM2V 5-80
L 27x600 zg-d	68000010	27	600	0,9	Gialla (Yellow)	PM/PMD/PMDVB 12-25-45 PMO 50-70 PMP 20 PMSE 20-30-40 PM2V 5-80
L 27x850 zb-d	68000011	27	850	1,2	Bianca (White)	PM/PMD/PMDVB 12-25-45 PMO 50-70 PMP 20 PMSE 20-30-40 PM2V 5-80
L 27x1000 zb-d	68000013	27	1000	1,5	Bianca (White)	PM/PMD/PMDVB 12-25-45 PMO 50-70 PMP 20 PMSE 20-30-40 PM2V 5-80

Leva standard : Ø27x600
zincata bianca (Standard lever : Ø27x600
white zinc-plating)

LEVA DRITTA (STRAIGHT LEVER)

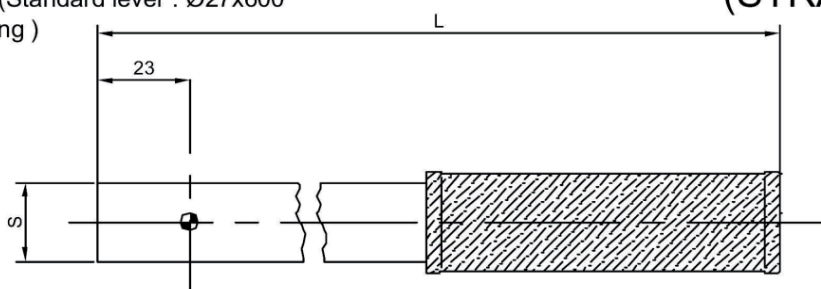

Tipo di leva Type of lever	CODICE CODE	Massa (Kg) Weight (Kg)	Zincatura Zinc-plating	Leva per tipo di pompa (Lever for type of pump)	A (mm)	B (mm)	C (°)	S (mm)	L (mm)
L 20x500 zb-p	68000019	0,4	Bianca (White)	PMSE 8-15	80	70	26°	20	380
L 27x600 zb-p	68000020	0,9	Bianca (White)	PM/PMD/PMDVB 12-25-45 PMO 50-70 PMP 20 PMSE 20-30-40 PM2V 5-80	140	100	31°	27	415

LEVA PIEGATA (FOLD LEVER)

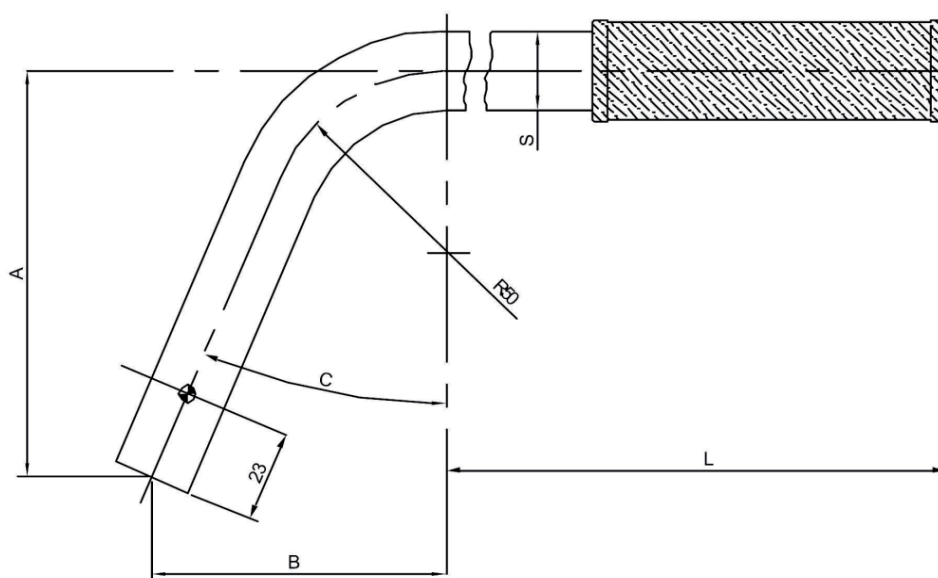

SERBATOI IN ACCIAIO VERNICIATO PER POMPE A MANO PAINTED STEEL OIL TANKS FOR HAND PUMP

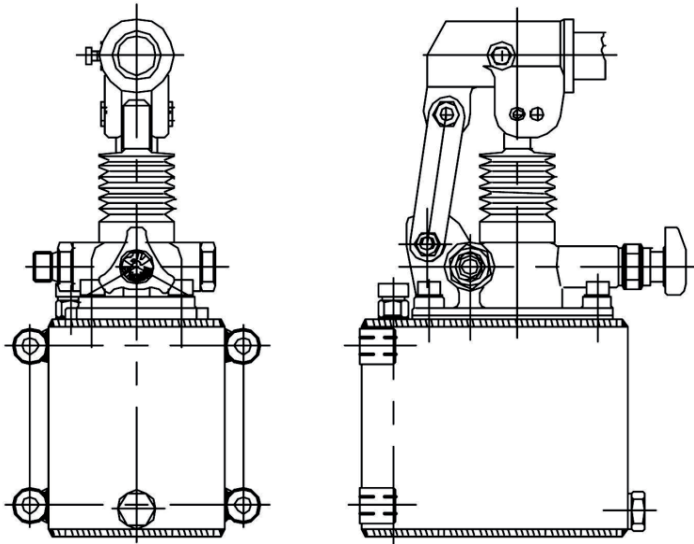

Montaggio verticale
(Vertical assembly)

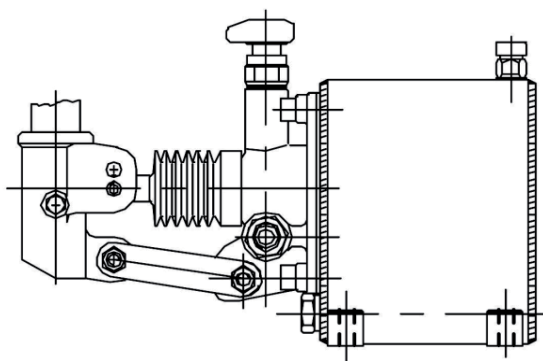

Montaggio orizzontale
(Horizontal assembly)

SERBATOI IN ACCIAIO VERNICIATO PER POMPE A MANO

PAINTED STEEL OIL TANKS FOR HAND PUMP

Capacità (litri) Capacity (litre)	CODICE CODE	A (mm)	B (mm)	C (mm)	D (mm)	Massa (Kg) Weight (Kg)	Tubo aspirazione Suction tube
1	65000081	100	150	120	120	2,2	Ø10x85 mm
2	65000082	100	150	185	120	3,0	Ø10x114 mm
3	65000083	100	150	255	120	3,7	Ø10x180 mm
5	65000084	175	175	200	195	5,3	Ø10x156 mm
7	65000085	175	175	275	195	6,6	Ø10x215 mm
10	65000086	175	175	380	195	8,3	Ø10x325 mm

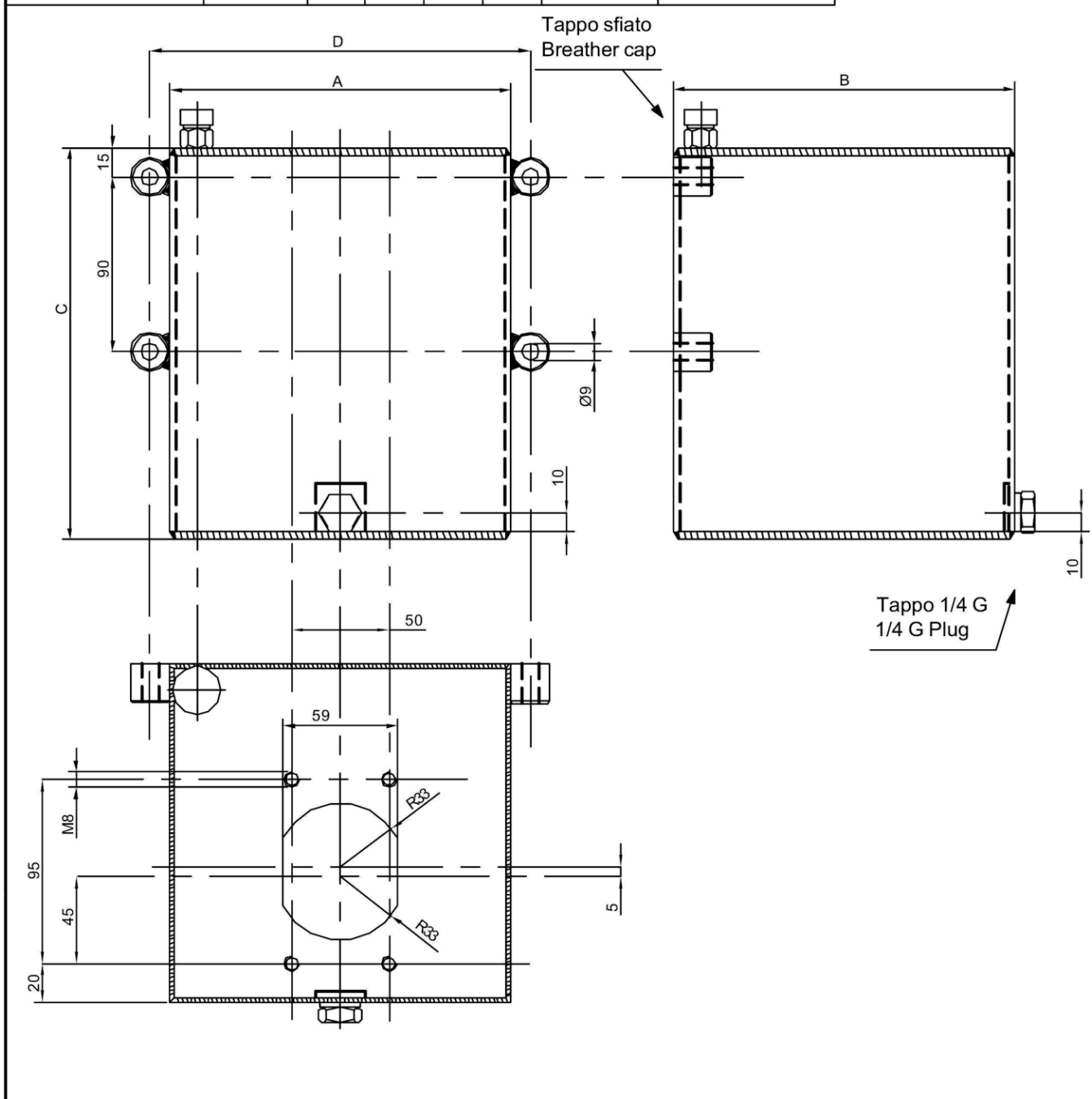

Fer Hydraulik s.r.l.
Via Lambrakis 16
42122 Reggio Emilia - Italy
Tel +39 0522 332177
Fax +39 0522 553891
info@fer-hydraulik.com - www.fer-hydraulik.com

